

Solicitation 22-42

On-Call Water and Sewer Line Repairs, Replacement and/or Rehabilitation Services

Bid Designation: Public

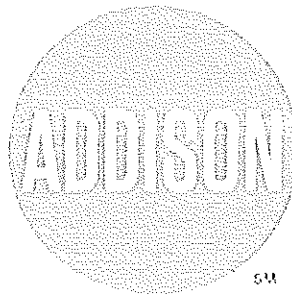

Town of Addison

Bid 22-42
On-Call Water and Sewer Line Repairs, Replacement and/or Rehabilitation Services

Bid Number **22-42**
Bid Title **On-Call Water and Sewer Line Repairs, Replacement and/or Rehabilitation Services**

Bid Start Date **Dec 10, 2021 2:43:23 PM CST**
Bid End Date **Jan 13, 2022 2:00:00 PM CST**
Question & Answer End Date **Jan 10, 2022 8:00:00 AM CST**

Bid Contact **Will Newcomer**
Purchasing Manager

Bid Contact **Diana Munoz**
Purchasing Specialist

Description

***NO FAX OR EMAIL SUBMITTALS ACCEPTED**

***THIS IS AN AS-NEEDED, WHEN-NEEDED CONTRACT AND NOT A GUARANTEE OF WORK.**

***THE TOWN MAY USE SOME, NONE, OR ALL OF THE SERVICES LISTED IN THIS SOLICITATION.**



BIDDING DOCUMENTS
FOR
ON-CALL WATER AND SEWER LINE REPAIRS, REPLACEMENT,
AND/OR REHABILITATION SERVICES
ANNUAL CONTRACT

TOWN OF ADDISON, TEXAS
BID NUMBER 22-42

I. Advertisement
Town of Addison
ON-CALL WATER AND SEWER LINE REPAIRS, REPLACEMENT,
AND/OR REHABILITATION SERVICES
RFP NO. 22-42

The Town of Addison, Texas requests competitive sealed proposals from qualified contractors, vendors or firms to provide **ON-CALL WATER AND SEWER LINE REPAIRS, REPLACEMENT, AND/OR REHABILITATION SERVICES – Annual Contract** within the town limits. Sealed Proposals will be accepted until 2:00 p.m., DATE at the Finance Building, 5350 Belt Line Rd., Dallas, Texas 75254 – Attention Purchasing Department, at which time offerors' names will be publicly read aloud. Late proposals will not be considered. The associated documents and other information are available on www.bidsync.com. The Town of Addison reserves the right to waive any formalities, to reject any and all proposals, and to select the proposal deemed most advantageous to the Town of Addison.

This Request for Proposals (RFP) is a complete sealed proposal method in accordance with the Texas Government Code Chapter 2269, Subchapter D.

Contractors should identify their proposal on the outside of the envelope by writing the words **"22-42 ON-CALL WATER AND SEWER LINE REPAIRS, REPLACEMENT, AND/OR REHABILITATION SERVICES."**

PAPER PROPOSALS SHALL BE REQUIRED. One (1) paper original hard copy signed by someone with signing authority for the contractor and one (1) electronic copy (USB preferred) should be submitted.

In lieu of a bid bond, proposals shall be accompanied by a completed Bonding Requirements Affidavit to show responding entities are bondable. The Bonding Affidavit shall be from a reliable surety company licensed by the State of Texas to act as a Surety and be listed on the current U.S. Treasury Listing of Approved Sureties.

Some work/jobs may exceed \$50k and therefore the awarded contractor(s) must be able to provide the appropriate bonds at that time.

Related documents may be downloaded from www.bidsync.com. The Town of Addison is a "free buyer", meaning that prospective offerors need only a free registration to sign up for plan updates. Offerors assume all risk for acquiring specs and/or plans from third party sites and plan rooms, as only www.bidsync.com will be directly updated by the Town Addison.

The right is reserved by the Mayor and the City Council as the interests of the Town may reject any or all proposals and to waive any formality in proposals received and to

select the proposal deemed most advantageous to the Town.

The Offeror (Proposer) must supply all the information required by the Proposal Form.

Throughout the term of this contract, the Town and awarded contractor will work together and identify when bonds are necessary and must provide to the Town (Performance Bond, Labor and Material Payment Bond, and Maintenance Bond). Bonds shall be issued by a surety company licensed by the State of Texas to act as a Surety and be listed on the current U.S. Treasury Listing of Approved Sureties.

The Offeror (Proposer) must supply all the information required by the Offeror Qualification Statement.

For information on the proposal or work to be performed, please submit all questions on www.bidsync.com. All questions must be received by 8:00am on January 10, 2022.

II. Introduction

A. PURPOSE OF THIS REQUEST FOR PROPOSAL

The Town of Addison Public Works Department is requesting sealed proposals from qualified contractors, vendors, or firms for on call water and sewer line leak repairs, replacement and/or rehabilitation services.

B. SCOPE OF WORK / GENERAL CONDITIONS

Town of Addison, Texas is experiencing a backup with leak repairs on their water and sanitary sewer lines, services, and appurtenances and are looking for a qualified firm to assist with these repairs on an as needed basis. The contact period will be effective for three (3) years from the date of award. The contract shall contain and option to extend the term of the agreement for three (3) additional one (1) year periods upon the same terms and conditions of the original bid. Each renewal period, if exercised and mutually agreed upon by both parties will be for one (1) additional year. Prices shall remain firm for one year and contractor will be granted a mutually agreed to annual price increase on bid items for the subsequent years. The Town will also have the right and option to terminate the agreement upon thirty (30) days written notice.

1. The Town is expected to award a primary contract and has the option to award a secondary contract if warranted to two separate firms.
2. Contractor shall be willing to enter into liability release agreements with the Town of Addison, Texas.
3. Contractor's performed services under this contract shall comply with all insurance requirements per Town of Addison and accepted prior to contract signatures.
4. The Contractor fully agrees to work in conjunction with the Town of Addison Public Works Department to correct any deficiencies in the repair or replacement of items initially identified.
5. The town owns several hundred miles of water and sanitary sewer lines. The infrastructure ranges in size from 42-inch diameter mains to ¾ inch service lines. The list of pipeline materials includes copper (CU), ductile iron (DI), cast iron (CI), reinforced concrete cylinder pipe (RCCP), pre-stressed concrete cylinder pipe (PCCP), Steel, and poly-vinyl chloride pipe (PVC).
6. The types of service that this contract could include but is not limited to is the following.
 - a. Point Repairs
 - b. Direct Replacement
 - c. Valve/hydrant replacement

- d. Manhole/wet well
 - e. Repair of damage structures
 - i. Concrete Street/Curb
 - ii. Landscape/irrigation
 - iii. ADA ramps
7. To be considered for selection, the company shall be qualified and capable of delivering any of the services identified above. If sub-contractors are to be used for any portion of the work, the sub-contractor shall be identified, and pertinent information related to their aspect of the team should be provided.
 8. The contractor shall furnish and install all necessary temporary works for the protection of the contracted work, including lights at night, barricades, and warning signs.
 9. Contractor is responsible for determining the exact location of all underground utilities and notifying DIG-TESS prior to any excavation work.
 10. The selected Company / companies will be contacted whenever the Town has a need for repairs to an existing water or sewer line or any associated appurtenances. Scope of work and other related details will be provided at the time of any request. The companies will then have 3 (three) calendar days to begin the repair. Prior to the third day and after the initial request the contractor will schedule a time to meet with Town representatives on site to determine scope of work, bid items to be utilized and construction schedule.
 11. There may be times when a project's urgency may require the Town to request responses within a shorter timeframe, which will be conveyed at the time of the request.
 12. If the Town repeatedly encounters quality issues or slow work from a selected company that are not resolved to the Town's satisfaction, the Town may discontinue requesting work from that company.
 13. Once the contract is awarded the Town reserves the right to request a repair be made based on Time and Materials if the repair does not match any bid items related to this document. Labor rates and material cost will be agreed to prior to commencing of work. The contractor is allowed a percent mark up on this type of work and is set per the bid item labeled "Percent mark up on Time and Materials cost."

III. INSTRUCTION TO BIDDERS

1.0 RECEIPT AND PREPARATION OF THE BID

- 1.1 Bids will be received by the Town of Addison until time specified in the Invitation to Bid. Bids must be received by the specified time to be considered. Bids cannot be submitted after this closing time. No changes may be made to bids after closing.
- 1.2 Bid responses SHALL be submitted in hard copy to the Finance Department address above. One (1) paper original hard copy signed by someone with signing authority for the contractor and one (1) electronic copy (USB preferred) should be submitted.
- 1.3 Bidders are responsible for submitting responses in a timely manner.
- 1.4 Bids may be withdrawn prior to the above scheduled time set for closing of the bids. Any bid received after the time and date specified will not be considered.
- 1.5 The Town of Addison reserves the right to postpone the date and time for opening bids through an addendum.
- 1.6 No changes to bid, including pricing structure, time to completion, and references may be made following submission of the bid packet.

2.0 ADDENDA AND EXPLANATIONS

- 2.1 Bidders having any questions regarding the true meaning of the specifications or terms and conditions shall submit these questions through the www.bidsync.com system. All addenda are issued through BidSync and acknowledgement must be returned with your bid.

3.0 TAXES

- 3.1 All bids are required to be submitted without State Sales tax. The Town of Addison is exempt from payment of such taxes and a Tax Exemption Certificate will be executed for the successful bidder.

4.0 EXAMINATION OF CONTRACT DOCUMENTS AND SITES

- 4.1 Before submitting a bid, each bidder must thoroughly examine the contract documents to ensure that the services you are proposing meet the intent of these specifications.
- 4.2 The Town of Addison is not responsible for incomplete bid packets.

5.0 BIDDING

- 5.1 Bidders are instructed to consider the following factors in preparation of your bid:
- a. Exceptions to any specifications, or part thereof, must be clearly stated and included with your response.
 - b. Bidders are instructed to include all necessary charges related to this solicitation.

6.0 AWARD OF CONTRACT

- 6.1 The Town of Addison reserves the right to accept or reject any bid without compensation to bidders and to waive irregularities and informalities. The Town of Addison will select the bidder(s) with the best overall value for the Town. The evaluation committee will open, read, and evaluate the submittals with each representative providing scores.

The selected best overall value will be based on the following criteria and associated value of each:

- Three (3) references for the contractors, vendors, or firms (30 points maximum) – Include with your submittal references for three (3) other clients in which you have provided similar services in the past 5 years. Include the name and contact information for the clients representative and describe the number and type of line repairs completed. (See bid form)
 - Price – lowest price receives maximum points (40 points maximum) – Each bid item will be evaluated, and value paid to the contractor based on theoretical quantities set by the evaluation team prior to receiving bids. The overall cumulative costs will be based on the total of the bid items. It is the intent of the Town to be billed monthly for services rendered. Any services provided outside of the scope must first be preapproved by Town staff. (See bid form)
 - Response Time/Restoration Time (30 points maximum) – provide the time it will take to gather resources and mobilize to site once notification has been received from the Town of Addison for repair work. Indicate the amount of time you will take on a standard repair item from the time the crews enter the site until it is fully restored. (See bid form)
- 6.2 Award will be based upon an analysis and scoring of criteria detailed above.
- 6.3 The anticipated start date is February-March 2022.

7.0 CERTIFICATES OF INSURANCE AND INDEMNIFICATION REQUIRED

- 7.1 Insurance and indemnification requirements are attached as a separate document and must be submitted with response. Submission of response confirms all requirements will be met within the time frame necessary.

8.0 RESOLUTION OF DISPUTES

- 8.1 Pursuant to subchapter I, Chapter 271, TEXAS LOCAL GOVERNMENT CODE, Contractor agrees that, prior to instituting any lawsuit or other proceeding arising from any dispute or claim of breach under this Agreement (a "Claim"), the parties will first attempt to resolve the Claim by taking the following steps: (i) A written notice substantially describing the factual and legal basis of the Claim shall be delivered by the Contractor to the Town within one-hundred eighty (180) days after the date of the event giving rise to the Claim, which notice shall request a written response to be delivered to the Contractor not less than fourteen (14) business days after receipt of the notice of Claim; (ii) if the response does not resolve the Claim, in the opinion of the Contractor, the Contractor shall give notice to that effect to the Town whereupon each party shall appoint a person having authority over the activities of the respective parties who shall promptly meet, in person, in an effort to resolve the Claim; (iii) if those persons cannot or do not resolve the Claim, then the parties shall each appoint a person from the highest tier of managerial responsibility within each respective party, who shall then promptly meet, in person, in an effort to resolve the Claim.

9.0 NON-DISCRIMINATION POLICY

- 9.1 It is the policy of the Town of Addison to afford all people an equal opportunity to bid on any contract being let by the Town.

The Town of Addison has a policy that prohibits discrimination against any person because of race, color, sex, or national origin, in the award or performance of any contract.

The Town of Addison will require its employees, agents, and contractors to adhere to this policy.

10.0 GENERAL CONDITIONS

- 10.1 Contractor will be subject to penalties if work is not completed by agreed upon time. The penalty amount will be based on the total construction price as laid out in the North Central Texas Council of Governments – Public Works Construction Standards (fifth edition) – section 108.8 Delays; Extension of Time; Liquidated Damages.
- 10.2 Before work begins, a pre-construction meeting will be arranged wherein the contractor and representative of the Town will discuss procedures for the work to be completed.

- 10.3 The contractor is responsible for supplying all equipment, labor, material, supervision, and traffic control as required in successfully completing repairs.
- 10.4 The contractor will provide, for Town approval, the names of material vendors and a copy of mix designs for concrete and HMAC.
- 10.5 The contractor shall designate a full-time Project Manager who shall be the one responsible for receiving the call when repairs are required. The Town's representative will communicate only with the Project Manager when services are required. The contractor may replace the designated project manager after notification to the Town.
- 10.6 The contractor will provide a list of names and twenty-four (24) hour emergency phone numbers for all key personnel related to the project.
- 10.7 The Town may request replacement of designated project manager after written notification to contractor.
- 10.8 The contractor is required to have a list of all subcontractors used submitted to the Town.
- 10.9 Normal work hours shall be limited to the period between 7:00 A.M. and 5:00 P.M. No work will be allowed on Saturdays or Sundays without a written request to, and approval from the Town at least forty-eight (48) hours in advance. No work will be allowed on Sundays, during Addison special event, or holidays (listed below).
- New Year's Day
 - Memorial Day
 - July Third and Fourth
 - Labor Day
 - Thanksgiving Day and Day after Thanksgiving
 - Christmas Eve and Day
 - Martin Luther King Day
 - Taste of Addison
 - Addison Kaboom Town
 - Addison Oktoberfest
- 10.10 During emergency situations working hours will be suspended by the Town and contractor notified of such approval.
- 10.11 The contractor hereby agrees to commence work on non-emergency repairs within three (3) working days of notice being given and complete the work on each group of repairs within the agreed upon time frame.
- 10.12 The Town of Addison Standard Details specifications, in combination with Federal and State ADA Specifications, and North Central Texas Council of Governments Standard Specifications for Public Works Construction (as adopted by the Town of Addison), shall govern all work performed in the Town of Addison. If a conflict arises, the inspector in charge of the project shall determine which specifications will be used. The contractor's field supervisor shall be required to obtain a copy of both,

at the contractor's expense. All invoices are to be submitted to the Town of Addison, 16801 Westgrove Drive, Addison, Texas 75001 or pweinvoices@addisontx.gov. The Town of Addison shall make payment within 30 days of receipt of invoice and acceptance of all goods and services by authorized town employees. Invoicing shall have the description of work done, be itemized according to the awarded unit cost. Unit cost shall not change for the initial first year.

- 10.13 The Town may wish to change the scope of this contract by adding or deleting goods or services. In this case, payments for extra work will be based upon agreed lump sums, agreed unit prices or time and materials with a markup. The Contractor and Town shall agree upon such prices before the extra work is started. The Contractor shall submit to the Town a written estimate of the cost of the extra work.

No Change Order shall be made without a written order from the Town of Addison, in which event the Contractor shall proceed with such extra work or change, and no claim for an addition to the Contract Sum shall be valid unless so ordered. All Change Orders which shall exceed the sum of \$50,000 or 25% of the original contract shall not be made without first obtaining City Council approval. All Change Orders less than \$50,000 or 25% of the original contract shall be first approved by the City Manager (or City Manager's designee) before such work shall be done. No employee of the Town shall have the right to waive or authorize Change Orders in contradiction to the above provisions. Notwithstanding any provision to the contrary contained in this agreement, Contractor shall not be entitled to claim any delay or additional compensation for the time which it takes to obtain the consents required herein.

- 10.14 No Waiver - One or more waivers to any covenant, term or condition of this Agreement by either party shall not be construed as a waiver of a subsequent breach of the same or any other covenant, term, or condition; nor shall any delay or omission by either party to seek a remedy for any breach of this Agreement or to exercise a right accruing to such party by reason of such breach be deemed a waiver by such party of its remedies or right with respect to such breach. The consent or approval by either party to or of any act by the other party requiring such consent or approval shall not be deemed to waive or render unnecessary consent to or approval of any similar act.
- 10.15 Entire Response Contractual Obligation – This response, submitted documents, and any negotiations, when properly accepted by the Town, shall constitute a contract equally binding between the successful vendor and Addison. No different or additional terms will become part of this contract except as properly executed in an addendum or change order.
- 10.16 Vendor shall familiarize themselves with the nature and extent of the specifications, site conditions and comply with all traffic and safety requirements, federal, state and local laws, ordinances, rules and

regulations that in any manner may affect cost, progress or performance of the Work.

- 10.17 The vendor agrees that they will retain personal control and will give their personal attention to the fulfillment of this contract and that they will not assign by Power of Attorney, or otherwise, or sublet said contract without the written consent of the Town of Addison, and that no part or feature of the work will be sublet to anyone objectionable to the Owner. The vendor further agrees that the subletting of any portion or feature of the work, or materials required in the performance of this contract, shall not relieve the vendor from their full obligations to the Owner.
- 10.18 Town of Addison and vendor each binds themselves, their partners, successors, assigns and legal representative to the other party hereto, his partners, successors, assigns and legal representatives in respect to all covenants, agreements and obligations contained in the Contract Documents.
- 10.19 The Contractor agrees to pay not less than the minimum wage rates established by law.
- 10.20 Interlocal Agreement: It is desirable for the successful bidder to agree to extend prices to all entities that have entered into or will enter into joint purchasing interlocal cooperation agreements with the Town. The Town is a participating member of several interlocal cooperative purchasing agreements. As such, the Town has executed interlocal agreements, as permitted under Chapter 791 and 271 of the Texas Government Code, with certain other political subdivisions, authorizing participation in a cooperative purchasing program. The successful supplier may be asked to provide products/services based upon the bid price, to any other participant.
- 10.21 Silence of Specifications: The apparent silence of these specifications as to any detail or to the apparent omission from it of a detailed description concerning any point, shall be regarded as meaning that only the best commercial practices are to prevail. All interpretations of these specifications shall be made on the basis of this statement.
- 10.22 Prior or pending litigation or lawsuits: Each supplier must include in its proposal a complete disclosure of any alleged significant prior or ongoing contract failures, any civil or criminal litigation or investigation pending which involves the proposer or in which the proposer has been judged guilty or liable.

11.0 TERMINATION OF AGREEMENT

- 11.1 BY TOWN: Failure to perform the work in accordance to the specifications shall constitute a material default. The Town of Addison, at

its sole option, shall have the right to terminate the contract without further cause.

- a. Should the Contractor at any time refuse or neglect to supply a sufficient number of properly skilled workmen or sufficient materials of the proper quality or fail in any respect to prosecute the work contemplated herein with promptness and diligence or fail in the performance of any of the covenants herein contained, or,
- b. If the Town is dissatisfied with the quality of the Contractor's performance, or if the Contractor fails to comply with the terms of this Agreement, the Town shall so inform the Contractor by telephone, noting all areas of dissatisfaction. The Contractor shall start the process of correcting the deficiencies by noon of the following day communicating the date of completion. If the Contractor fails to correct the deficiencies within the said period, the Town may elect to:
 1. Perform the services itself, or obtain others to perform the services, in which case the Town shall recover those costs by deducting 200% of the "out of pocket expense" from the Contractor's monthly invoice; and/or,
 2. Terminate the Agreement immediately by giving written notice to the Contractor. Termination by the Town under this section shall be in addition to all other remedies that the Town may have against the Contractor.
 3. The Town of Addison reserves the right to cancel this agreement, without cause with 10 days written notice.
 4. The Town may be required to cancel the contract if the governing body does not provide funding for any fiscal year beginning October 1.

11.2 BY CONTRACTOR

- a. Should the Contractor elect to cancel the Contract prior to the original or extended termination date, at least sixty (60) days written notice shall be given to the Purchasing Manager of the Town of Addison.
- b. The Town shall deduct any out-of-pocket costs, associated with re-bidding this contract, from money owed the Contractor. Also, any cost of services for the balance of the contract term shall be deducted by the Town from amounts owed to the Contractor.

12.0 Warranty

- 12.1 All work performed under this contract for the Town and Addison shall be warranted for a period of two (2) years. If within (2) years after

acceptance of work, any of the work is found to be defective or not in accordance with the contract documents, the contractor shall correct it promptly after receipt of notice from the Town.

- 12.2 Some work may require bonds. The Town will work with the awarded contractor to identify these circumstances.

IV. General Construction Specifications Town of Addison

A. Traffic Control

- a. The contractor shall provide warning signs, barricades, channeling devices, and flagmen as needed to provide for the safety of the traveling public. Traffic control may include, but is not limited to, lane closures, detours, and road closings. A traffic control plan in conformance with the latest version of the "Texas Manual on Uniform Traffic Control Devices for Street and Highways" (TMUTCD) must be submitted for each separate street where work will be performed. Free-hand drawings will not be accepted.
- b. The contractor shall ensure that each person whose actions affect temporary traffic control work zone safety, from upper-level management through field personnel, has received training appropriate to the job decision each individual is required to make concerning traffic control. All traffic control devices shall be used in accordance with the guidelines in the latest revision of the TMUTCD.
- c. All barricades, plastic drums, channelizers, cones, and construction signing shall comply with the requirements of the current "Texas Department of Transportation Barricading and Construction Standards" sheets.
- d. During repair of sidewalks an alternate pedestrian access route shall be provided according to Federal and State ADA requirements. All sidewalk repairs will have ADA compliant barricades with "Sidewalk Closed-Use Other Side" signs at the beginning and end of each excavation site. No signs will be allowed on the sidewalk outside of the closed area.
- e. Interruption with the flow of traffic on major arterials is only permitted between 9:00A and 3:30P under normal conditions. Work times outside of this window must be approved by the Town.
- f. Stop/Slow paddles will be used in all flagging operations.
- g. Flagging personnel must meet the qualifications as stated in the TMUTCD.

- h. No streets shall be closed to traffic without written approval from the Town.
- i. All construction signing shall be reflective and "like new" in appearance. The Town may require that signs be replaced which do not meet these requirements.
- j. "Construction Ahead" and "End of Construction" signs are required to be installed prior to the start of construction.
- k. Routine inspection of traffic control for each project is the responsibility of the contractor and shall be performed daily according to the latest version of TMUTCD. Traffic control inspections will be required on holidays, weekends, and non-workdays as well.
- l. Construction signing shall not be removed from the work zone until approved by the Town.

B. Temporary Construction Water Meter

All water required for the project will be at the CONTRACTOR'S expense. The CONTRACTOR shall obtain a temporary water meter (deposit reimbursed when the meter is returned) from the OWNER and meter all water used for the project.

The contractor shall contact the Finance Department, for construction loan meter application and contractor shall make required deposit. A service request will be sent to the Town of Addison Service Center located at 16801 Westgrove Drive for the temporary water meter. Service Requests for water meters take 24 hours to process. Contractor is responsible for paying temporary meter deposit and all water usage required for this project. Deposit will be reimbursed once the meter is returned.

C. Paving/Drainage/Sidewalk/Landscaping/Barrier Free Ramps

1. Any repairs needed to the surrounding area caused by leak repairs shall be in accordance with Town Standard Construction Details that is found on the website below.

<https://addisontexas.net/ckeditorfiles/files/Infrastructure-Engineering-Standard-Construction-Details-Paving.pdf>

2. Asphalt mix designs shall follow NCTCOG PWCS, Standard Specifications and Standard Drawings Item 302 "Asphalt Pavement"
3. All storm drainage installation shall follow Town of Addison Standard Construction Details for "Storm Drainage" that is found on the website below.

<https://addisontexas.net/ckeditorfiles/files/Infrastructure-Engineering-Standard-Construction-Details-Storm-Drainage.pdf>

4. All barrier free ramps consist of curb cuts, ramps, return curbs, landings, flares, and saw cuts. The pay item will be by each, to include all items considered part of the ramp, as defined in the above statement. Sidewalk transition will be paid as sidewalk repair. The Town of Addison shall decide the layout of the ramp components for each ramp location. The contractor will be responsible for ensuring ramps are built to meet all state and federal requirements. If the layout causes a conflict with ADA requirements, contractor shall inform the inspector of the conflict. **Any changes to the layout must still ensure full compliance to federal and state ADA requirements.**
5. Detectable warnings
 - a. Detectable warnings shall be cast in place (wet set). The inspector will determine which type will be used during the layout of the ramp. They shall be twenty-four (24) inches in depth in the direction of pedestrian travel, and full width of the ramp.
 - b. All detectable warnings shall be Tekway ADA Systems or approved equivalent. The color shall be terra cotta.

D. Construction Plans

Task Orders for work associated with this contract may not be accompanied by construction plans. In this case the Contractor will be responsible for following the Town's standard specifications and details. From time to time, the Contractor may be provided engineered plans and specifications for a project. The Contractor will be responsible for providing unit bid pricing as laid out in the provided specifications and bid form.

E. Sediment Control

Contractor is required to meet all Stormwater requirements and will be required to utilize and maintain best management practices at all times.

F. Equipment Left on Jobsite

No equipment shall be left on the jobsite overnight. **All equipment will be required to carry fire extinguishers in case of emergency.**

G. Joint and Crack Sealants

Joint sealant shall follow NCTCOG PWCS, Standard Specifications and Standard Drawings Item 303.2.14 "Joint Sealant".

Crack sealant shall follow NCTCOG PWCS, Standard Specifications and Standard Drawings Item 401 "Crack Sealing".

H. General Construction Notes

1. The contractor is responsible for compliance with all laws and regulations regarding the prevention of underground utility damage. The contractor is also responsible for reporting to the appropriate operator any damage to underground utilities during the course of work.
2. The Contractor will be responsible for contacting DIGTESS prior to any excavation.
3. The Contractor shall mark the saw cut and excavation limit on each repair site with a Town representative present.
4. Removal of integral curb will be included in the unit price of concrete pavement removal.
5. No sidewalk repair will be smaller than four feet by four feet (4' x 4').
6. No curb and gutter, or integral curb repair will be smaller than five (5) linear feet.
7. All paving shall be saw cut along neat lines prior to removal. Any pavement that is chipped or broken outside saw cuts will be repaired as determined by the inspector and at the contractor's expense.
8. All excavated earth in excess of that required for back filling shall be removed from the job site and disposed of in a satisfactory manner except in locations where, in the judgement of the Town or property owner, it can be neatly spread over the adjacent area. No stockpiling of material in the street will be allowed after work hours. The cost for this is subsidiary to the pavement repair.
9. Topsoil will be used to level up excavated areas to receive sod.
10. The contractor shall remove all trees, stumps, brush and other debris or deleterious material generated as part of this work. Proper disposal of these items is the sole responsibility of the contractor.
11. Delays associated with the delivery of material will not be considered for any extension of contract time. It shall be the contractor's responsibility to ensure that all materials are delivered on time.

12. No concrete shall be placed at any job site until the contractor has notified the Town's representative and requested and received an inspection of the site. The contractor shall request such inspection at least twenty-four (24) hours prior to concrete being placed. Any concrete placed without an inspection shall be removed and replaced at the contractor's expense.
13. Bar chairs to support reinforcing steel and dowel rods shall be used in repairs as required.
14. Tooled joints in sidewalk will not be sealed. All other joints will be sealed.
15. All inlets within the project limits, and any that may be affected by runoff from the repair area, will be protected. The Town's inspector will determine if any inlet needs to be cleaned due to runoff from the area.
16. The areas adjacent to construction shall be returned to their original condition. The contractor should use every effort to avoid damage. If damage does occur it is the responsibility of the contractor to repair any damage landscaping, sprinkler systems, or other items affected by the repair.
17. Damage to sprinkler systems will be addressed promptly and in the following manner: contractor will inform Town inspector and property owner of damage. Upon completion of repairs, contractor will inform property owner and Town inspector and set up time to run system to verify repairs are satisfactory.

Note: Once the damage has been identified, the contractor will repair the damage within 48 hours and verify with the customer that the system has been restored to its original condition. IT IS THE CONTRACTOR'S RESPONSIBILITY TO VERIFY THAT AN IRRIGATION SYSTEM HAS BEEN RETURNED TO ITS ORIGINAL CONDITION with the resident, business owner, etc. If condition of the irrigation system has not been verified, payment for that month may be withheld (at the inspector's discretion). Any sod that must be installed due to the construction will be installed within a reasonable time period.

18. Repairs to water service lines cut during construction on the customer's side of the meter will be completed by a Licensed Plumber at the expense of the contractor.

19. The contractor is responsible for insuring density of sub-grade meets towns specifications for each repair. Lack of testing does not relieve the contractor of this responsibility.
20. The contractor will make every effort to match existing sod on all repairs.
21. The line item for crushed rock subgrade is intended for special projects and will only be used at the discretion of the inspector. The line item includes the contractor providing, placing, and compacting the crushed rock subgrade.
22. Contractor's vehicles shall contain company name and information displayed properly on the side.
23. Labors shall have a uniform identifying who they are working for.

V. Proposal Form

Proposals will be scored by an evaluation committee consisting of Town staff. Proposals will be scored with regards to the following criteria and associated weights:

- **Price:** Evaluation will award up to 40 points based on pricing with low bid receiving all 40 points.
 - **Previous Performance:** Evaluation will award up to 30 points based on past performance contracts with public agencies and private industry in terms of quality of work, and compliance with performance schedules. List three previous contracts and include the name, address, telephone number, and email address of the point of contact representing the public or private entity for each contract. Contractor is allowed to use the Town of Addison as a reference.
 - **Response Time/Restoration Time:** All contractors responding to the synopsis will be considered, however, evaluations will award up to 30 points based on time it will take to gather resources and mobilize to site once notification has been received from the Town of Addison for repair work. Restoration time is based on the amount of time indicated to make a standard repair from the time the crews enter the site until it is fully restored.
- Price - 40%
 - Experience and Past Previous Performance - 30%
 - Response Time/Restoration Time - 30%

PROPOSAL FORM

TO: The Honorable Mayor and
Town Council Town of
Addison, Texas

The undersigned Offeror, having examined the plans, specifications and contract documents, and the location of the proposed work, and being fully advised as to the extent and character of the work, proposes to furnish all material, equipment and to perform all labor and work necessary for completion of the work described by and in accordance with the Contract Documents and Contract for the following prices, to wit:

Sig

Printed
Name: David Martinez



Title: General Partner

Business
Name: Rey-Mar Construction

Date: 01/13/22

ACKNOWLEDGMENT OF ADDENDA:

The Offeror acknowledges receipt of the following addenda:

Addendum No. 1 _____

Addendum No. 2 _____

Addendum No. 3 _____

**PROPOSAL FORM
REFERENCES**

Reference #1

Entity Name: Trophy Club Municipal Utility District
Type of Work performed: Utilities, water, wastewater, lift station, pump stations
Address: 100 Municipal Drive, Trophy Club, TX 76262
Point of Contact: Mike McMahan
Title: Director of Public Works
Phone Number: 817.538.1872
Email: mmcmahon@tcmud.org

Reference #2

Entity Name: Troy Hopkins, City of Venus, Texas. 817.401.8120
Type of Work performed: Force main, lift station improvements
Address: 700 West US 67, Venus, TX 76084
Point of Contact: Troy Hopkins
Title: Director of Public Works
Phone Number: 817.401.8120
Email: thopkins@cityofvenus.org

Reference #3

Entity Name: City of Rhome, Texas
Type of Work performed: Wastewater treatment plant improvement, expansion
Address: 501 South Main St., Rhome, TX 76078
Point of Contact: Sean Densmore
Title: Director of Public Works
Phone Number: 817.913.5361
Email: publicworks@cityofrhome.com

**PROPOSAL FORM
RESPONSE TIME/RESTORATION TIME**

Project Manager Assigned to project on daily basis

Name: _____

This proposal is requesting a maximum 72 hours from time of notification to commencement of work.

How many working days would it take to schedule an onsite meeting, gather equipment, materials, and laborers to repair a leak on an 8' deep, 24" PVC water main located under a concrete four-lane divided throughfare. Time stated should be from notification to completed repair and restoration of surrounding site.

Assumptions:

- One lane closure during non-working hours and two-lane closure during working hours.
- Line can be isolated and drained without interference.
- Length of pipe to be replace is 5 feet.
- Depth of pipe is 8 feet.
- Pavement replacement is 15' x 12' panel with 15 feet of curb.
- High early strength concrete is acceptable.

Proposed Time NON-EMERGENCY:

A.	Representative on site to assess the work	<u>2 hrs</u> (Hrs)
B.	From notification to mobilized on site	<u>1</u> (days)
C.	Pavement removal, excavation, repair, backfill	<u>2</u> (days)
D.	From pavement replacement to open to traffic	<u>1</u> (days)

Proposed Time EMERGENCY:

E.	Representative on site to assess the work	<u>3</u> (Hrs)
F.	From notification to mobilized on site	<u>3</u> (Hrs)
G.	Pavement removal, excavation, repair, backfill	<u>6</u> (Hrs)
H.	From pavement replacement to open to traffic	<u>2</u> (days)

**PROPOSAL FORM
LITIGATION/LAWSUITS**

Contractor to list any prior or pending litigation or lawsuits. If none, then list as N/A

NA

**PROPOSAL FORM
SUBCONTRACTORS**

Contractor to list any services to be performed by Sub. List legal name of sub and type of work they are to perform. If no subs are to be used, then list as N/A.

Tommy Electric, HH Electric, HC Electric. Electrical work

Odessa Pumps, bypass pumping setup, rental of pumps

BID FORM

Item No	Item Description	Unit	Unit Bid Price	Total Bid Price For Evaluation
WATER MAIN				
1	Trench Safety		INCIDENTAL TO OTHER BID ITEMS	
2	Repair 1-inch or smaller water service up to 20 feet in length including all excavation, backfilling, utility adjustment, pipe embedment, including all incidentals necessary to complete	EA	5,200	5,200
3	Repair 1-1/4-inch to 2-inch water service up to 20 feet in length including all excavation, backfilling, utility adjustment, pipe embedment, including all incidentals necessary to complete	EA	6,300	6,300
4	Repair 6-inch water main up to 5 feet in length, (0-6-feet deep), including excavation, backfilling, testing, pipe embedment and other incidentals necessary to complete	EA	8,800	8,800
5	Repair 6-inch water main up to 5 feet in length, (above 6-feet deep), including excavation, backfilling, testing, pipe embedment and other incidentals necessary to complete	EA	8,800	8,800
6	Repair 8-inch water main up to 5 feet in length, (0-6-feet deep), including excavation, backfilling, testing, pipe embedment and other incidentals necessary to complete	EA	9,800	9,800
7	Repair 8-inch water main up to 5 feet in length, (above 6-feet deep), including excavation, backfilling, testing, pipe embedment and other incidentals necessary to complete	EA	9,800	9,800
8	Repair 10-inch water main up to 5 feet in length, (0-6-feet deep), including excavation, backfilling, testing, pipe embedment and other incidentals necessary to complete	EA	11,250	11,250
9	Repair 10-inch water main up to 5 feet in length, (above 6-feet deep), including excavation, backfilling, testing, pipe embedment and other incidentals necessary to complete	EA	11,250	11,250
10	Repair 12-inch water main up to 5 feet in length, (0-6-feet deep), including excavation, backfilling, testing, pipe embedment and other incidentals necessary to complete	EA	14,300	14,300
11	Repair 12-inch water main up to 5 feet in length, (above 6-feet deep), including excavation, backfilling, testing, pipe embedment and other incidentals necessary to complete	EA	14,300	14,300
12	Repair 16-inch water main up to 5 feet in length, (0-6-feet deep), including excavation, backfilling, testing, pipe embedment and other incidentals necessary to complete	EA	19,400	19,400
13	Repair 16-inch water main up to 5 feet in length, (above 6-feet deep), including excavation, backfilling, testing, pipe embedment and other incidentals necessary to complete	EA	19,400	19,400
14	Repair 24-inch water main up to 5 feet in length, (0-6-feet deep), including excavation, backfilling, testing, pipe embedment and other incidentals necessary to complete	EA	29,000	29,000
15	Repair 24-inch water main up to 5 feet in length, (above 6-feet deep), including excavation, backfilling, testing, pipe embedment and other incidentals necessary to complete	EA	29,000 43,500 a.u.	29,000 43,500 a.u.
16	Repair 36-inch water main up to 5 feet in length, (0-6-feet deep), including excavation, backfilling, testing, pipe embedment and other incidentals necessary to complete	EA	43,500 56,250 a.u.	43,500 56,250 a.u.
17	Repair 36-inch water main up to 5 feet in length, (above 6-feet deep), including excavation, backfilling, testing, pipe embedment and other incidentals necessary to complete	EA	43,500	43,500
18	Repair 42-inch water main up to 5 feet in length, (0-6-feet deep), including excavation, backfilling, testing, pipe embedment and other incidentals necessary to complete	EA	56,250	56,250

19	Repair 42-inch water main up to 5 feet in length, (above 6-feet deep), including excavation, backfilling, testing, pipe embedment and other incidentals necessary to complete	EA	56,250	56,250
20	Remove and replace fire hydrant with WaterMaster 5CD250 Fire Hydrant 6" MJ Shoe by EJ per city specifications, including excavation, backfilling, testing, embedment and other incidentals necessary to complete	EA	12,850	12,850
21	Remove and replace existing 6-inch valve with 6-inch resilient seat gate valve per city specifications, including excavation, backfilling, testing, embedment and other incidentals necessary to complete	EA	6,200	6,200
22	Remove and replace existing 8-inch valve with 8-inch resilient seat gate valve per city specifications, including excavation, backfilling, testing, embedment and other incidentals necessary to complete	EA	6,500	6,500
23	Remove and replace existing 10-inch valve with 10-inch resilient seat gate valve per city specifications, including excavation, backfilling, testing, embedment and other incidentals necessary to complete	EA	7,900	7,900
24	Remove and replace existing 12-inch valve with 12-inch resilient seat gate valve per city specifications, including excavation, backfilling, testing, embedment and other incidentals necessary to complete	EA	9,700	9,700
25	Remove and replace existing 16-inch valve with 16-inch resilient seat gate valve per city specifications, including excavation, backfilling, testing, embedment and other incidentals necessary to complete	EA	13,750	13,750
SANITARY SEWER MAIN				
26	Trench Safety		INCIDENTAL TO OTHER BID ITEMS	
27	Repair 6-inch or smaller sanitary sewer service up to 10 feet in length including all excavation, backfilling, utility adjustment, pipe embedment, by-pass pumping and other incidentals necessary to complete	EA	13,800	13,800
28	Repair 6-inch sanitary sewer main up to 10 feet in length, (0-6-feet deep), including excavation, backfilling, testing, pipe embedment, by-pass pumping and other incidentals necessary to complete	EA	14,700	14,700
29	Repair 6-inch sanitary sewer main up to 10 feet in length, (above 6-feet deep), including excavation, backfilling, testing, pipe embedment, by-pass pumping and other incidentals necessary to complete	EA	14,400	14,400
30	Repair 8-inch sanitary sewer main up to 10 feet in length, (0-6-feet deep), including excavation, backfilling, testing, pipe embedment, by-pass pumping and other incidentals necessary to complete	EA	15,000	15,000
31	Repair 8-inch sanitary sewer main up to 10 feet in length, (above 6-feet deep), including excavation, backfilling, testing, pipe embedment, by-pass pumping and other incidentals necessary to complete	EA	14,650	14,650
32	Repair 10-inch sanitary sewer main up to 10 feet in length, (0-6-feet deep), including excavation, backfilling, testing, pipe embedment, by-pass pumping and other incidentals necessary to complete	EA	16,250	16,250
33	Repair 10-inch sanitary sewer main up to 10 feet in length, (above 6-feet deep), including excavation, backfilling, testing, pipe embedment, by-pass pumping and other incidentals necessary to complete	EA	15,900	15,900
34	Repair 12-inch sanitary sewer main up to 10 feet in length, (0-6-feet deep), including excavation, backfilling, testing, pipe embedment, by-pass pumping and other incidentals necessary to complete	EA	19,750	19,750
35	Repair 12-inch sanitary sewer main up to 10 feet in length, (above 6-feet deep), including excavation, backfilling, testing, pipe embedment, by-pass pumping and other incidentals necessary to complete	EA	19,350	19,350
TRAFFIC CONTROL				
36	Steel Plates 6' x 10'	DAY	60	60
37	Steel Plates 8' x 10'	DAY	70	70

38	Traffic Control for residential streets includes emplacement traffic control, signing, barricading and all other incidentals necessary per project according to town guidelines and the MUTCD standards	DAY	300		300
39	Traffic Control for Collector streets includes emplacement traffic control, signing, barricading and all other incidentals necessary per project according to town guidelines and the MUTCD standards	DAY	420		420
40	Traffic Control for Arterial streets includes emplacement traffic control, signing, barricading and all other incidentals necessary per project according to town guidelines and the MUTCD standards	DAY	520		520
PAVING					
41	Remove and replace 8-inch concrete street as per city specifications, including all incidentals necessary	SY	400		400
42	Remove and replace 10-inch concrete street as per city specifications, including all incidentals necessary	SY	450		450
43	Remove and replace 6-inch concrete curb as per city specifications, including all incidentals necessary	LF	11		11
44	Remove and replace reinforced concrete barrier free ramp as per city specifications, including all incidentals necessary	EA	3,250		3,250
45	Remove and replace reinforced concrete sidewalk as per city specifications, including all incidentals necessary	SF	4 ⁹⁸ 8 P.M.		98
46	Remove and replace concrete curb and gutter per city specifications, including all incidentals necessary	LF	16		16
47	Remove and replace 6-inch HMA Type B or C pavement per city specifications, including all incidentals necessary	SY	400		400
48	Crushed rock subgrade placement including all incidentals necessary to complete in place for pavement stabilization		INCIDENTAL TO OTHER BID ITEMS		
49	Bermuda sod w/topsoil	SY	1.90		1.90
50	St. Augustine sod w/topsoil	SY	2.50		2.50
MOBILIZATION					
51	Standard Mobilization per work order	EA	2,000		2,000
52	Emergency Mobilization per work order	EA	4,400		4,400
MISCELLANEOUS					
53	Proposed Annual percentage of price escalation per year after year one is complete	%	5%		5%
54	Proposed percent mark up on Time and Material costs	%	10%		10%

By submitting a bid in response to this solicitation, the bidder certifies that their firm is not debarred, suspended, or otherwise ineligible for participation in government procurement by the federal government, the State of Texas, or any other state, county, or municipal government.

The undersigned has caused this bid to be executed as of the day and year indicated above.

REY-MAX CONSTRUCTION
 Printed Name

GENERAL PARTNER
 Title

817-535-3451 / 817-438-3537
 Phone

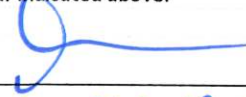
 Signature DAVID MARTINEZ

DAVID E. REY-MAX CONSTRUCTION, L.P.
 Email

817-535-0153
 Fax

CONTRACT AGREEMENT

STATE OF TEXAS

COUNTY OF DALLAS

THIS AGREEMENT is made and entered into this _____ day of _____, 2020, by and between the Town of Addison, of the County of Dallas and State of Texas, acting through its City Manager, thereunto duly authorized so to do, Party of the First Part, hereinafter termed the OWNER, and _____, of the City of _____, County of _____, State of _____, Party of the Second Part, hereinafter termed CONTRACTOR.

WITNESSETH: That for and in consideration of the payment and agreement hereinafter mentioned, to be made and performed by the OWNER, the said CONTRACTOR hereby agrees with the said OWNER to commence and complete construction of certain improvements as follows:

ON-CALL WATER AND SEWER LINE REPAIRS, REPLACEMENT, AND/OR REHABILITATION SERVICES – ANNUAL CONTRACT

PUBLIC WORKS AND ENGINEERING SERVICES BID NUMBER 22-42

and all extra work in connection therewith, under the terms as stated in the General and Specific Conditions of the AGREEMENT; and at his own proper cost and expense to furnish all the materials, supplies, machinery, equipment, tools, superintendence, labor, insurance and other accessories and services necessary to complete the said construction, in accordance with the conditions and prices stated in the Proposal attached hereto and in accordance with the Advertisement for Bids, Instructions to Bidders, General Provisions, Special Provisions, Plans, and other drawings and printed or written explanatory matter thereof, and the Technical Specifications and Addenda thereto, as prepared by the OWNER, each of which has been identified by the endorsement of the CONTRACTOR and the OWNER thereon, together with the CONTRACTOR’s written Proposal and the General Provisions, all of which are made a part hereof and collectively evidence and constitute the entire AGREEMENT.

The CONTRACTOR hereby agrees to commence work as stated in the within the scope of work/general conditions after the date of written notice to do so shall have been given to him, to complete the work within time specified after he commences work, subject to such extensions of time as are provided by the General Provisions.

The OWNER agrees to pay the CONTRACTOR _____ Dollars (\$_____) in current funds for the performance of the Contract in accordance with the Proposal submitted thereof,

subject to additions and deductions, as provided in the General Provisions, and to make payments of account thereof as provided therein.

IN WITNESS WHEREOF, the parties of these presents have executed this AGREEMENT in the year and day first above written.

TOWN OF ADDISON, TEXAS (OWNER)

ATTEST:

By: _____
City Manager

By: _____

(CONTRACTOR)

ATTEST:

By:  _____

By:  _____

The following to be executed if the CONTRACTOR is a corporation:

I, _____ certify that I am the secretary of the corporation named as CONTRACTOR herein; that _____, who signed this Contract on behalf of the CONTRACTOR is the _____ (official title) of said corporation; that said Contract was duly signed for and in behalf of said corporation by authority of its governing body, and is within the scope of its corporate powers.

Signed: _____

Corporate Seal

WaterMaster® 5CD250 Fire Hydrant 6" MJ Shoe

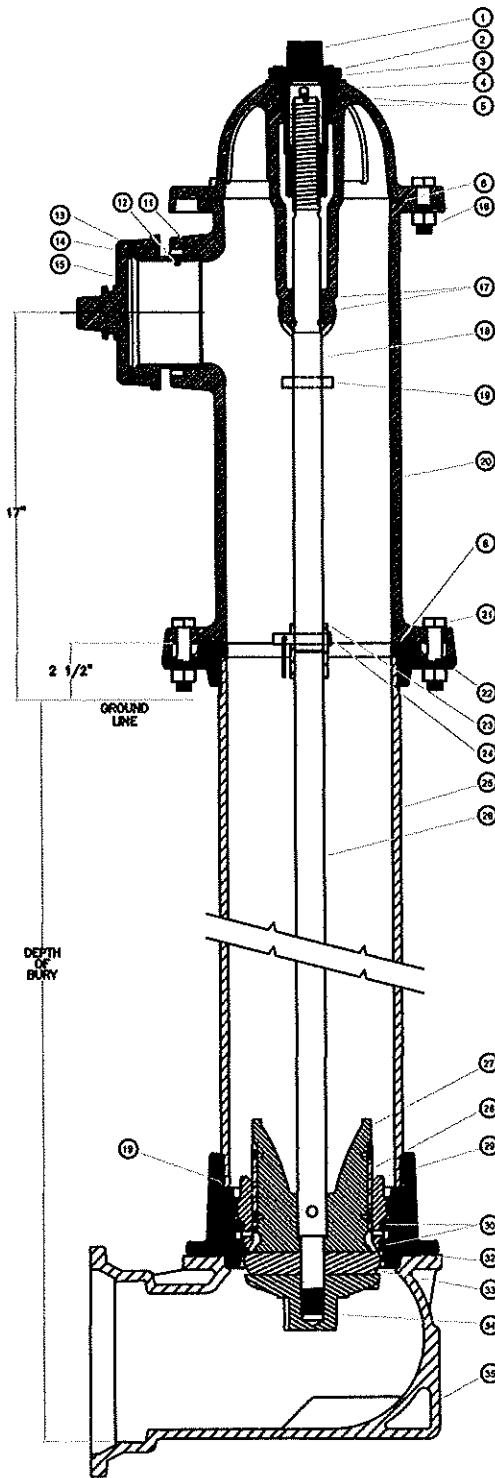

Product
WaterMaster® 5CD250 Fire Hydrant
Design Features

1. RATED WORKING PRESSURE = 250 PSI.
2. MEETS ANSI/AWWA C502.
3. UL LISTED/FM APPROVED.

Components

CAT NO.	PARTS LIST	MATERIAL
1	OPERATING NUT	BRONZE
2	HOLD DOWN NUT	BRONZE
3	WEATHER SEAL "O" RING	BUNA-N
4	TOP BONNET	D.I.
5	THRUST WASHER	DELRIN
6	QUAD RINGS*	BUNA-N
7	HOSE NOZZLE "O" RING**	BUNA-N
8	HOSE NOZZLE**	BRONZE
9	HOSE NOZZLE GASKET**	RUBBER
10	HOSE NOZZLE CAPS**	C.I.
11	PUMPER NOZZLE "O" RING	BUNA-N
12	PIPE PLUG 1/4 NPTF SS HEX	STN. STL.
13	PUMPER NOZZLE GASKET	RUBBER
14	PUMPER NOZZLE	BRONZE
15	PUMPER NOZZLE CAP	C.I.
16	TOP BONNET BOLTS & NUTS	ZINC PL. GR. 8
17	RESERVOIR "O" RING	BUNA-N
18	OPERATING STEM TOP 24 1/4"	STEEL W/BRASS SLEEVE
19	DRIVE-LOC PIN	STN. STL.
20	NOZZLE STANDPIPE	D.I.
21	SAFETY FLG. BOLTS & NUTS	ZINC PL. GR. 8
22	SWIVEL FLANGES (FRANGIBLE)	C.I.
23	STEM COUPLING (FRANGIBLE)	GALV. STL.
24	COUPLING PIN & RING COTTER	STN. STL.
25	STANDPIPE LOWER SECTION	D.I. W/BRONZE INSERT
26	OPERATING STEM LOWER	STEEL
27	HIGH PRESSURE DRIP SHUTOFF	BRONZE
28	INSERTS	HOPE
29	VALVE SEAT	BRONZE
30	VALVE SEAT "O" RING	BUNA-N
31	BRASS DRAIN HOLE BUSHING**	BRASS
32	INLET FLANGE "O" RING	BUNA-N
33	SEATING VALVE RUBBER	RUBBER
34	VALVE WASHER	D.I./EPOXY
35	BOTTOM INLET	D.I./EPOXY
36	INLET FLG. BOLTS & NUTS**	STN. STL. 18-8
37	CHAINS**	ZN. PL. STL.
38	SET SCREW (1/4 - 20 SS CONE PT)**	STN. STL.
39	INSERT SCREWS**	STN. STL.

* NOT A REPLACEMENT PART
** NOT SHOWN

Drawing Revision
Designer: MWP 08/25/20
Revised By:

Disclaimer

Weights (lbs /kg) dimensions (inches/mm) and drawings provided for your guidance. We reserve the right to modify specifications without prior notice.

CONFIDENTIAL: This drawing is the property of EJ GROUP, Inc., and embodies confidential information, registered marks, patents, trade secret information, and/or know how that is the property of EJ GROUP, Inc. Copyright © 2020 EJ GROUP, Inc. All rights reserved.

Contact
800 626 4653
ejco.com

Attached

THIS FORM MUST BE TURNED IN WITH YOUR BID

BID REQUIREMENT AFFIDAVIT

TO BE COMPLETED BY APPROPRIATE BONDING AGENT.

I, the undersigned agent, certify that the bonding requirements contained in this bid document have been reviewed by me with the vendor identified below. If the vendor identified below is awarded this contract by the Town of Addison, I will be able, within ten (10) working days after being notified of such award, to furnish the required payment, performance, and maintenance bonds to the TOWN meeting all of the requirements contained in this bid.

Agent Signature Printed Name

Name of Insurance Carrier

Address of Agency City State Zip

Phone # Fax # Email Address

Vendor / Contractor Name

Acknowledgement

Subscribed and Sworn before me by the above named _____

On this _____ day of _____, 2019.

(seal)

Notary Public in and for the State of _____

NOTICE TO THE AGENT

If this time requirement is not met, the City/Town has the right to declare this vendor non-responsible and award the contract the next lowest/responsible bidder meeting the specifications. If you have any questions concerning these requirements, please contact Wil Newcomer, Town of Addison Purchasing at 972-450-7091.

TOWN OF ADDISON, TEXAS
CONTRACTOR INSURANCE REQUIREMENTS & AGREEMENT

REQUIREMENTS

Contractors performing work on TOWN OF ADDISON property or public right-of-way shall provide the TOWN OF ADDISON a certificate of insurance or a copy of their insurance policy(s) (and including a copy of the endorsements necessary to meet the requirements and instructions contained herein) evidencing the coverages and coverage provisions identified herein within ten (10) days of request from TOWN OF ADDISON. Contractors shall provide TOWN OF ADDISON evidence that all subcontractors performing work on the project have the same types and amounts of coverages as required herein or that the subcontractors are included under the contractor's policy. Work shall not commence until insurance has been approved by TOWN OF ADDISON.

All insurance companies and coverages must be authorized by the Texas Department of Insurance to transact business in the State of Texas and must have a A.M. Best's rating A-:VII or greater.

Listed below are the types and minimum amounts of insurances required and which must be maintained during the term of the contract. TOWN OF ADDISON reserves the right to amend or require additional types and amounts of coverages or provisions depending on the nature of the work.

TYPE OF INSURANCE	AMOUNT OF INSURANCE	PROVISIONS
1. Workers' Compensation Employers' Liability to include: (a) each accident (b) Disease Policy Limits (c) Disease each employee	Statutory Limits per occurrence Each accident \$1,000,000 Disease Policy Limits \$1,000,000 Disease each employee \$1,000,000	<u>TOWN OF ADDISON to be provided a WAIVER OF SUBROGATION AND 30 DAY NOTICE OF CANCELLATION or material change in coverage.</u> Insurance company must be A-:VII rated or above.
2. Commercial General (Public) Liability to include coverage for: a) Bodily Injury b) Property damage c) Independent Contractors d) Personal Injury e) Contractual Liability	Bodily Injury/Property Damage per occurrence \$1,000,000, General Aggregate \$2,000,000 Products/Completed Aggregate \$2,000,000, Personal Advertising Injury per occurrence \$1,000,000, Medical Expense 5,000	<u>TOWN OF ADDISON to be listed as ADDITIONAL INSURED and provided 30 DAY NOTICE OF CANCELLATION or material change in coverage.</u> Insurance company must be A-:VII rated or above.
3. Business Auto Liability to include coverage for: a) Owned/Leased vehicles b) Non-owned vehicles c) Hired vehicles	Combined Single Limit \$1,000,000	<u>TOWN OF ADDISON to be listed as ADDITIONAL INSURED and provided 30 DAY NOTICE OF CANCELLATION or material change in coverage.</u> Insurance company must be A-:VII-rated or above.

Certificate of Liability Insurance forms (together with the endorsements necessary to meet the requirements and instructions contained herein) may be **faxed** to the Purchasing Department: **972-450-7074** or **emailed to: purchasing@addisontx.gov**. Questions regarding required insurance should be directed to the Purchasing Manager.

With respect to the foregoing insurance,

1. All liability policies shall contain no cross liability exclusions or insured versus insured restrictions applicable to the claims of the Town of Addison.

2. All insurance policies shall be endorsed to require the insurer to immediately notify the Town of Addison, Texas of any material change in the insurance coverage.
3. All insurance policies shall be endorsed to the effect that the Town of Addison, Texas will receive at least thirty (30) days' notice prior to cancellation or non-renewal of the insurance.
4. All insurance policies, which name the Town of Addison, Texas as an additional insured, must be endorsed to read as primary coverage regardless of the application of other insurance.
5. Insurance must be purchased from insurers that are financially acceptable to the Town of Addison and licensed to do business in the State of Texas.

All insurance must be written on forms filed with and approved by the Texas Department of Insurance. Upon request, Contractor shall furnish the Town of Addison with complete copies of all insurance policies certified to be true and correct by the insurance carrier.

This form must be signed and returned with your quotation. You are stating that you do have the required insurance and if selected to perform work for TOWN OF ADDISON, will provide the certificates of insurance (and endorsements) with the above requirements to TOWN OF ADDISON within 10 working days.

A CONTRACT/PURCHASE ORDER WILL NOT BE ISSUED WITHOUT EVIDENCE AND APPROVAL OF INSURANCE.

AGREEMENT

I agree to provide the above described insurance coverages within 10 working days if selected to perform work for TOWN OF ADDISON. I also agree to require any subcontractor(s) to maintain insurance coverage equal to that required by the Contractor. It is the responsibility of the Contractor to assure compliance with this provision. The TOWN accepts no responsibility arising from the conduct, or lack of conduct, of the Subcontractor.

Project/Bid# 22-42

Company: Rey-Mar Construction

Printed Name: David Martinez

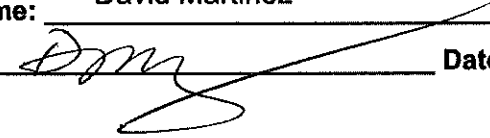
Signature:  Date: 01/13/22

Town of Addison

Indemnification Agreement

Contractor's Indemnity Obligation. Contractor covenants, agrees to, and shall DEFEND (with counsel reasonably acceptable to Owner), INDEMNIFY, AND HOLD HARMLESS Owner, its past, present and future elected and appointed officials, and its past, present and future officers, employees, representatives, and volunteers, individually or collectively, in both their official and private capacities (collectively, the "Owner Persons" and each being an "Owner Person"), from and against any and all claims, liabilities, judgments, lawsuits, demands, harm, losses, damages, proceedings, suits, actions, causes of action, liens, fees (including attorney's fees), fines, penalties, expenses, or costs, of any kind and nature whatsoever, made upon or incurred by Owner and/or Owner Person, whether directly or indirectly, (the "Claims"), that arise out of, result from, or relate to: (i) the services to be provided by Contractor pursuant to this Agreement, (ii) any representations and/or warranties by Contractor under this Agreement, (iii) any personal injuries (including but not limited to death) to any Contractor Persons (as hereinafter defined) and any third persons or parties, and/or (iv) any act or omission under, in performance of, or in connection with this Agreement by Contractor or by any of its owners, directors, officers, managers, partners, employees, agents, contractors, subcontractors, invitees, patrons, guests, customers, licensees, sublicensees, or any other person or entity for whom Contractor is legally responsible, and their respective owners, directors, officers, directors, officers, managers, partners, employees, agents, contractors, subcontractors, invitees, patrons, guests, customers, licensees, sublicensees (collectively, "Contractor Persons"). SUCH DEFENSE, INDEMNITY AND HOLD HARMLESS SHALL AND DOES INCLUDE CLAIMS ALLEGED OR FOUND TO HAVE BEEN CAUSED IN WHOLE OR IN PART BY THE NEGLIGENCE OR GROSS NEGLIGENCE OF OWNER OR ANY OTHER OWNER PERSON, OR CONDUCT BY OWNER OR ANY OTHER OWNER PERSON THAT WOULD GIVE RISE TO STRICT LIABILITY OF ANY KIND.

Contractor shall promptly advise Owner in writing of any claim or demand against any Owner Person related to or arising out of Contractor's activities under this Agreement and shall see to the investigation and defense of such claim or demand at Contractor's sole cost and expense. The Owner Persons shall have the right, at the Owner Persons' option and own expense, to participate in such defense without relieving Contractor of any of its obligations hereunder. This defense, indemnity, and hold harmless provision shall survive the termination or expiration of this Agreement.

The provisions in the foregoing defense, indemnity and hold harmless are severable, and if any portion, sentence, phrase, clause or word included therein shall for any reason be held by a court of competent jurisdiction to be invalid, illegal, void, or unenforceable in any respect, such invalidity, illegality, voidness, or unenforceability shall not affect any other provision thereof, and this defense, indemnity and hold harmless provision shall be considered as if such invalid, illegal, void, or unenforceable provision had never been contained in this Agreement. **In that regard, if the capitalized language included in the foregoing indemnity is so determined to be void or unenforceable, the parties agree that:**

(i) the foregoing defense, indemnity, and hold harmless obligation of Contractor shall be to the extent Claims are caused by, arise out of, or result from, in whole or in part, any act or omission of Contractor or any Contractor Persons; and

(ii) notwithstanding the provisions of the foregoing subparagraph (i), to the fullest extent permitted by law, Contractor shall INDEMNIFY, HOLD HARMLESS, and DEFEND Owner and Owner Persons from and against all Claims arising out of or resulting from bodily injury to, or sickness, disease or death of, any employee, agent or representative of Contractor or any of its subcontractors, regardless of whether such Claims are caused, or are alleged to be caused, in whole or in part, by the negligence, or any act or omission, of Owner or any Owner Persons, it being the expressed intent of Owner and Contractor that IN SUCH EVENT THE CONTRACTOR'S INDEMNITY, HOLD HARMLESS, AND DEFENSE OBLIGATION SHALL AND DOES INCLUDE CLAIMS ALLEGED OR FOUND TO HAVE BEEN CAUSED IN WHOLE OR IN PART BY THE NEGLIGENCE OR GROSS NEGLIGENCE OF OWNER OR ANY OTHER OWNER PERSON, OR CONDUCT BY OWNER OR ANY OTHER OWNER PERSON THAT WOULD GIVE RISE TO STRICT LIABILITY OF ANY KIND. The indemnity obligation under this subparagraph (ii) shall not be limited by any limitation on the amount or type of damages, compensation, or benefits payable by or for Contractor under workers compensation acts, disability benefit acts, or other employee benefit acts.

I understand that the indemnification provisions are required of all Town of Addison Contracts. I have read the provisions and agree to the terms of these provisions.

Project/Bid#: 22-42

Company Name: Rey-Mar Construction

Signature: 

Date: 01/13/22

FINANCE

Interested Parties

In 2015, the Texas Legislature adopted House Bill 1295, which added section 2252.908 of the Government Code. The law states that a governmental entity or state agency may not enter into certain contracts with a business entity unless the business entity submits a disclosure of interested parties to the governmental entity or state agency at the time the business entity submits the signed contract to the governmental entity or state agency. The law applies only to a contract of a governmental entity or state agency that either (1) requires an action or vote by the governing body of the entity or agency before the contract may be signed or (2) has a value of at least \$1 million. The disclosure requirement applies to a contract entered into on or after January 1, 2016.

The Texas Ethics Commission was required to adopt rules necessary to implement that law, prescribe the disclosure of interested parties form, and post a copy of the form on the commission's website. The commission adopted the Certificate of Interested Parties form (Form 1295) on October 5, 2015. The commission also adopted new rules (Chapter 46) on November 30, 2015, to implement the law.

Filing Process

On January 1, 2016, the commission made available on its website a new filing application that must be used to file Form 1295. A business entity must use the application to enter the required information on Form 1295 and print a copy of the completed form, which will include a certification of filing that will contain a unique certification number. An authorized agent of the business entity must sign the printed copy of the form and have the form notarized. The completed Form 1295 with the certification of filing must be filed with the governmental body or state agency with which the business entity is entering into the contract.

The governmental entity or state agency must notify the commission, using the commission's filing application, of the receipt of the filed Form 1295 with the certification of filing not later than the 30th day after the date the contract binds all parties to the contract. The commission will post the completed Form 1295 to its website within seven business days after receiving notice from the governmental entity or state agency.

Information regarding how to use the filing application will be available on this site by January 1, 2016. https://www.ethics.state.tx.us/whatsnew/elf_info_form1295.htm, please follow Instructional Video for Business Entities.

Town of Addison

REQUEST FOR PROPOSAL TERMS AND CONDITIONS

1. **APPLICABILITY:** These standard Terms and Conditions and the Terms and Conditions, Specifications, Drawings and other requirements included in the Town of Addison's Request for Proposal (collectively, "Terms and Conditions") are applicable to Contracts/Purchase Orders issued by the Town of Addison (hereinafter referred to as the "Town" or "Buyer") and the Seller (herein after referred to as the "Seller," "Proposer," "Contractor," or "Supplier"). Any deviations must be in writing and signed by a representative of the Town's Purchasing Department and the Supplier. No Terms and Conditions contained in the Seller's Proposal, Invoice or Statement shall serve to modify the terms set forth herein. If there is a conflict between the Terms and Conditions and the provisions on the face of the Contract/Purchase Order, the Terms and Conditions will take precedence and control.

2. **OFFICIAL PROPOSAL NOTIFICATION:** The Town utilizes the following for official notifications of proposal opportunities: www.bidsync.com and the Dallas Morning News of Dallas County. These are the only forms of notification authorized by the Town. The Town is not responsible for receipt of notifications or information from any source other than those listed. It shall be the Supplier's responsibility to verify the validity of all Request for Proposal information received from any source other than the Town. There will be NO COST to the Seller for using BidSync for its Bids/Proposals.

3. **PRIOR OR PENDING LITIGATION OR LAW SUITS:** Each Proposer must include in its proposal a complete disclosure of any alleged significant prior or ongoing contract failures, any civil or criminal litigation or investigation pending which involves the Proposer or in which the Proposer has been judged guilty or liable.

4. **COST OF RESPONSE:** Any cost incurred by the Supplier in responding to the Request for Proposal is the responsibility of the supplier and cannot be charged to the Town.

5. **PROHIBITION AGAINST PERSONAL INTEREST IN CONTRACTS:** No Town of Addison employee shall have a direct or indirect financial interest in any contract with the Town, or be directly or indirectly financially interested in the sale of land, materials, supplies or services to the Town.

6. **COMPETITIVE PRICING:** It is the intent of the Town to consider Interlocal Cooperative Agreements and State/Federal contracts in determining the best value for the Town.

7. **INTERLOCAL AGREEMENT:** The successful Proposer agrees to extend prices to all entities that have entered into or will enter into joint purchasing interlocal cooperation agreements with the Town. The Town is a participating member of several interlocal cooperative purchasing agreements. As such, the Town has executed interlocal agreements, as permitted under Chapter 791 of the Texas Government Code, with certain other political subdivisions, authorizing participation in a cooperative purchasing program. The successful Supplier may be asked to provide products/services based upon terms and conditions of award, to any other participant in a cooperative purchasing program.

8. **CORRESPONDENCE:** The proposal number must appear on all correspondence and inquiries pertaining to the Request for Proposal. The Purchase Order number must appear on all invoices or other correspondence relating to the contract.

9. **INDEMNITY/INSURANCE:** See attached Town of Addison minimum requirements.

10. **ERROR-QUANTITY:** Proposals must be submitted in units of quantity specified, extended, and totaled. In the event of discrepancies in extension, the unit prices shall govern.

11. **ACCEPTANCE:** The right is reserved to accept or reject all or part of the proposal or offer, and to accept the proposal or offer considered most advantageous to the Town by line item or total offer or proposal.

12. **PROPOSAL LIST REMOVAL:** The Town reserves the right to remove a Supplier from any Proposal list for: (1) continued failure to be responsive to the Town, (2) failure to deliver merchandise within promised time, (3) delivery of substandard merchandise, or (4) failure to comply with the Contract/Purchase Order requirements.

13. **CONTRACT RENEWAL OPTIONS:** In the event a clause for option to renew for an additional period is included in the Request for Proposal, all renewals will be based solely upon the option and agreement between the Town and the Supplier. Either party dissenting will terminate the contract in accordance with its initial specified term.

14. **TAXES-EXEMPTION:** All quotations are required to be submitted LESS Federal Excise and State Sales Taxes. Tax Exemption Certificate will be executed for the successful Supplier.

15. **ASSIGNMENT AND SUCCESSORS:** The successful Supplier shall not assign, transfer, pledge, subcontract, or otherwise convey, in any manner whatsoever, any contract resulting from this proposal, in whole or in part, without the prior written consent of the Town of Addison.

16. **INVOICING:** Send ORIGINAL INVOICE to address indicated on the contract/purchase order. If invoice is subject to cash discounts the discount period will begin on the day invoices are received. So that proper cash discount may be computed, invoice should show amount of freight as a separate item, if applicable; otherwise, cash discount will be computed on total amount of invoice.

17. **ELECTRONIC SIGNATURE – UNIFORM ELECTRONIC TRANSACTION ACT:** The Town adopts Texas Business and Commerce Code Chapter 322, Uniform Electronic Transactions Act, allowing individuals, companies, and governmental entities to lawfully use and rely on electronic signatures.

18. **FUNDING OUT CLAUSE:** This agreement or contract may be terminated by the Town without notice and without penalty or liability in the event that (1) the Town lacks sufficient funds for this agreement or contract; (2) funds for this agreement or contract are not appropriated by the Town Council of the Town; and (3) funds for this agreement or contract that are or were to be provided by grant or through an outside service are withheld, denied or are otherwise not available to the Town.

19. **DISPUTE RESOLUTION:** Pursuant to subchapter 1, Chapter 271, TEXAS LOCAL GOVERNMENT CODE, Contractor agrees that, prior to instituting any lawsuit or other proceeding arising from any dispute or claim of breach under this Agreement (a "Claim"), the parties will first attempt to resolve the Claim by taking the following steps: (i) A written notice substantially describing the factual and legal basis of the Claim shall be delivered by the Contractor to the Town within one-hundred eighty (180) days after the date of the event giving rise to the Claim, which notice shall request a written response to be delivered to the Contractor not less than fourteen (14) business days after receipt of the notice of Claim; (ii) if the response does not resolve the Claim, in the opinion of the Contractor, the Contractor shall give notice to that effect to the Town whereupon each party shall appoint a person having authority over the activities of the respective parties who shall promptly meet, in person, in an effort to resolve the Claim; (iii) if those persons cannot or do not resolve the Claim, then the parties shall each appoint a person from the highest tier of managerial responsibility within each respective party, who shall then promptly meet, in person, in an effort to resolve the Claim.

20. **DISCLOSURE OF CERTAIN RELATIONSHIPS:** Chapter 176 of the Texas Local Government Code requires that any person, as defined in the statute, considering doing business with a local government entity disclose in the Questionnaire Form CIQ, the supplier or person's affiliation or business relationship that might cause a conflict of interest with a local government entity. By law, this questionnaire must be filed with the Records Administrator of the Town not later than the 7th business day after the later of (a) the date the person (i) begins discussions or negotiations to enter into a contract with the local governmental entity, or (b) submits to the local governmental entity an application, response to a request for proposals or bids, correspondence, or another writing related to a potential contract with the local governmental entity, or (b) the date the person becomes aware (i) of an employment or other business relationship with a local government officer, or a family member of the officer, described by the statute, or (ii) that the person has given one or more gifts described in the statute. See Section 176.006, Local Government Code. A person commits an offense if the person violates Section 176.006, Local Government Code. An offense under this section is a Class C misdemeanor. The questionnaire may be found at www.ethics.state.tx.us/forms/CIQ.pdf

By submitting a response to this request, Supplier represents that it is in compliance with the requirements of Chapter 176 of the Texas Local Government Code.

21. **PATENTS:** Seller agrees to indemnify and hold harmless the Buyer against all costs and expenses, including but not limited to attorneys fees, and undertakes and agrees to defend at seller's own expense, all suits, actions or proceedings in which Buyer or the users of Buyer's products are claimed to have conducted in, or are made defendants of, actual or alleged infringement of any U.S. or foreign patent or other intellectual property right resulting from the use or sale of the items purchased hereunder and further agrees to pay and discharge any and all judgments or decrees which may be rendered in any such suit, action or proceeding.

22. **APPLICABLE LAW:** This agreement shall be governed by the laws of the State of Texas, including but not limited to the Uniform Commercial Code as adopted by the State of Texas, as effective and in force on the date of this agreement, without regard to its conflict of laws rules or the conflict of law rules of any other jurisdiction.

23. **VENUE:** This agreement is performable in Dallas County, Texas, and venue for any suit, action, or legal proceeding under or in connection with this agreement shall lie exclusively in Dallas County, Texas. Proposer submits to the exclusive jurisdiction of the courts in Dallas County, Texas for purposes of any such suit, action, or proceeding hereunder, and waives any claim that any such suit, action, or legal proceeding has been brought in an inconvenient forum or that the venue of that proceeding is improper.

24. **TERMINATION FOR CAUSE OR CONVENIENCE:** The Town at any time after issuance of this agreement, by 30 days written notice to the Supplier, has the absolute write to terminate this agreement for cause or for convenience (that is, for any reason or no reason whatsoever). "Cause" shall be the Supplier's refusal or failure to satisfactorily perform or complete the work within the time specified, or failure to meet the specifications, quantities, quality and/or other requirements specified in the Contract/Purchase Order. In such case the Supplier shall be liable for any damages suffered by the Town. If the agreement is terminated for convenience, the Supplier has no further obligation under the agreement. Payment shall be made to cover the cost of material and work in process or "consigned" to the Town as of the effective date of the termination.

25. **FORCE MAJEURE:** To the extent either the Town or Proposer shall be wholly or partially prevented from the performance of this agreement or of any obligation or duty under this agreement placed on such party, by reason of or through work strikes, stoppage of labor, riot, fire, flood, acts of war, insurrection, court judgment, act of God, or other specific cause reasonably beyond the party's control and not attributable to its malfeasance, neglect or nonfeasance, then in such event, such party shall give notice of the same to the other party (specifying the reason for the prevention) and the time for performance of such obligation or duty shall be suspended until such disability to perform is removed.

26. **BAFO:** During evaluation process Town reserves the right to request a best and final offer upon completion of negotiations.

27. **PROTECTION OF TRADE SECRETS OR PROPRIETARY INFORMATION:** Proposals will be received and publicly acknowledged at the location, date, and time stated. Sellers, their representatives and interested persons may be present. The proposals shall be received and acknowledged only so as to avoid disclosure of the contents to compelling sellers and kept secret

during negotiation. However, all proposals shall be open for public inspection after the contract is awarded. Trade secrets and confidential information contained in the proposal and identified by Seller in writing as such will be treated as confidential by the Town to the extent allowable in the Texas Public Information Act and other law.

28. **SILENCE OF SPECIFICATIONS:** The apparent silence of these specifications as to any detail or to the apparent omission from it of a detailed description concerning any point, shall be regarded as meaning that only the best commercial practices are to prevail. All interpretations of these specifications shall be made on the basis of this statement.

29. **PROPOSAL RESPONSE CONTRACTUAL OBLIGATION:** This proposal, submitted documents, and any negotiations, when properly accepted by the Town, shall constitute a contract equally binding between the successful Proposer and the Town. No different or additional terms will become part of this contract except as properly executed in an addendum or change order.

30. **NO BOYCOTTING ISRAEL.** The entity contract with the Town of Addison does not boycott Israel and will not boycott Israel during the term of the contract. Reference HB 89 as it relates to Chapter 2270 of the Texas Government Code. Boycott Israel means refusing to deal with, terminating business activities with, or otherwise taking any action that is intended to penalize, inflict economic harm on, or limit commercial relations specifically with Israel or with a person or entity doing business in Israel or in an Israeli-controlled territory, but does not include an action made for ordinary business purposes.

31. **NO INDUSTRY DISCRIMINATION.** The entity contracting with the Town of Addison does not discriminate against firearm and ammunition industries during the term of the contract. Reference SB 19 as it relates to Chapter 2251 of the Texas Government Code. Discriminating means refusing to deal with, terminating business activities with, or otherwise taking any action that is intended to penalize, inflict economic harm on, or limit commercial relations specifically with the firearm or ammunition industry or with a person or entity doing business in the firearm or ammunition industry, but does not include an action made for ordinary business purposes.

Information and Instruction Form

RESPONSES THAT DO NOT CONTAIN THIS COMPLETED FORM MAY NOT BE COMPLIANT

Section I Company Profile

Name of Business: **Rey-Mar Construction**

Business Address: **3416 Reed St. Fort Worth, TX 76119**

Contact Name: **David Martinez**

Phone#: **817.938.3537**

Fax#:

Email: **david@reymarconstruction.com**

Name(s) Title of Authorized Company Officers: **David Martinez, Oscar Martinez, JL Rubio**

Federal ID #: W-9 Form: A W-9 form will be required from the successful bidder.

DUN #: **869294306**

Remit Address: If different than your physical address:

Section II Instructions to Bidders

Electronic Bids: The Town of Addison uses BidSync to distribute and receive bids and proposals. There will be **NO COST** to the Contractor/Supplier for Standard bids or proposals. For **Cooperative Bids and Reverse Auctions ONLY**, the successful contractor/supplier agrees to pay BidSync a transaction fee of one percent (1%) of the total amount of all contracts for goods and/or services. **Cooperative Bids and Reverse Auctions** will be clearly marked on the bid documents. To assure that all contractors/suppliers are treated fairly, the fee will be payable whether the bid/proposal is submitted electronically, or by paper means. Refer to www.bidsync.com for further information.

Contractor/Supplier Responsibility: It is the contractor/suppliers responsibility to check for any addenda or questions and answers that might have been issued before bid closing date and time. Contractors/Suppliers will be

notified of any addenda and Q&A if they are on the invited list, they view the bid, or add themselves to the watch list.

Acknowledgement of Addenda: #1 #2 #3 #4 #5

Delivery of Bids: For delivery of paper bids our physical address is:

Town of Addison

5350 Beltline Road

Dallas, TX 75254

Attn: Purchasing Department

Contractor/Supplier Employees: No Contractor/Supplier employee shall have a direct or indirect financial interest in any contract with the town, or be directly or indirectly financially interested in the sale of land, materials, supplies or services to the town.

Deliveries: All deliveries will be F.O.B. Town of Addison. All Transportation Charges paid by the contractor/supplier to Destination.

Payment Terms: A Prompt Payment Discount of % is offered for Payment Made Within Days of Acceptance of Goods or Services. If Prompt Payments are not offered or accepted, payments shall be made 30 days after receipt and acceptance of goods or services or after the date of receipt of the invoice whichever is later.

Delivery Dates: Delivery Dates are to be specified in Calendar Days from the Date of Order.

Bid Prices: Pre-Award bid prices shall remain Firm and Irrevocable for a Period of _____ Days.

Exceptions: Contractor/Supplier does not take Exception to Bid Specifications or Other Requirements of this Solicitation. If neither exceptions box is checked, default shall be "No Exceptions"

Contractor/Supplier take the following Exception(s) to the Bid Specifications or Other Requirements of this Solicitation (Explain in Detail). If box checked but no exceptions are listed, default shall be "No Exceptions"

Historically Underutilized Business (HUB): It is the policy of the Town of Addison to involve HUBs in the procurement of goods, equipment, services and construction projects. Prime Contractors/Suppliers are encouraged to provide HUBs the opportunity to compete for sub-contracting and other procurement opportunities. A listing of HUBs in this area may be accessed at the following State of Texas Website.

<http://www.window.state.tx.us/procurement/cmb/cmbhub.html>.

HUB Owned Business Yes No Include a current copy of your HUB certification with your response or insert Certification number _____ and expire date _____.

Other Government Entities: Would bidder be willing to allow other local governmental entities to participate in this contract, if awarded under the same Terms and Conditions? Yes No

Bid Bond: Is Bid Bond attached if applicable? Yes No

Termination: The town at any time after issuance of this agreement, by 30 days written notice, has the absolute right to terminate this agreement for cause or convenience. Cause shall be the contractor/supplier's refusal or failure to satisfactorily perform or complete the work within the time specified, or failure to meet the specifications, quantities, quality and/or other requirements specified in the contract/purchase order. In such case the supplier shall be liable for any damages suffered by the town. If the agreement is terminated for convenience, the supplier has no further obligation under the agreement. Payment shall be made to cover the cost of material and work in process or "consigned" to the town as of the effective date of the termination.

Bidder Compliance: Bidder agrees to comply with all conditions contained in this Information and Instruction Form and the additional terms and conditions and specifications included in this request. The undersigned hereby agrees to furnish and deliver the articles or services as specified at the prices and terms herein stated and in strict accordance with the specifications and conditions, all of which are made a part of your offer. Your offer is not subject to withdrawal after the award is made.

The Town of Addison reserves the right to reject all or part of the offer and to accept the offer considered most advantageous to the town by item or total bid.

The Town of Addison will award to the lowest responsible bidder or to the bidder who provides goods or services at the best value for the Town.

I hereby certify that all of the information provided in sections I and II are true and accurate to the best of my knowledge.

Signature: Date: 01/13/22



Title: General Partner

Signature certifies no changes have been made to the content of this solicitation as provided by the Town of Addison.

10/17/17

Question and Answers for Bid #22-42 - On-Call Water and Sewer Line Repairs, Replacement and/or Rehabilitation Services

Overall Bid Questions

Question 1

Is there an estimated cost range? (Submitted: Dec 10, 2021 4:31:09 PM CST)

Answer

- As stated in the bid documents this is an "as needed" contract. The anticipated spending for repairs during 2022 is budgeted at \$150,000. (Answered: Dec 13, 2021 9:02:29 AM CST)