

Solicitation 20-231

Addison Airport CBP Facility Furniture & Installation Services

Bid Designation: Private



Town of Addison

Bid 20-231

Addison Airport CBP Facility Furniture & Installation Services

Bid Number	20-231
Bid Title	Addison Airport CBP Facility Furniture & Installation Services
Bid Start Date	Sep 29, 2020 12:16:12 PM CDT
Bid End Date	Oct 7, 2020 8:00:00 AM CDT
Question & Answer End Date	Oct 5, 2020 12:00:00 PM CDT
Bid Contact	Wil Newcomer Purchasing Manager
Bid Contact	Michele Griffin Accounting Specialist Finance

Description

Please, refer to OMNIA Partners cooperative contract pricing R191813. The attached specifications with quantities is the Town's best estimate of actual need. The Town reserves the right to modify or not modify actual quantities ordered.



Furniture Dealer Scope of Services

Once furniture Dealers are awarded, they are expected to participate with the Project Manager, the A/E, and General Contractor in coordination of furniture milestones within the construction schedule. Upon event multiple dealers are awarded to a single project, coordination of all dealers furniture milestone schedules will need to be provided by the A/E or Project Manager and then coordinated with the General Contractor.

Confirm requirements with Project Manager as scope and size of project will inform extent of dealer services. Weekly meetings may be required for large or specialty projects but not for medium or small projects.

The furniture dealers shall provide:

- The awarded furniture scope to allow Owner move-in by proposed installation date
- Furniture specific drawings, representing all furniture awarded to Dealer
- Assigned representative to attend weekly construction meetings as necessary to coordinate schedules for furniture delivery and installation. Representative shall be thoroughly familiar with the work and may be contacted for duration of project to act as a liaison between Contractor, Owner and A/E.
- Proposed project schedule indicating compliance with proposed installation dates. Installation dates are mandatory and cannot be delayed for any reason.
- Floor core confirmation of accuracy in alignment with furniture award
- Coordination, through General Contractor, of electrician and data cabling contractors to align activities required to attach furniture to base building services

Dealer to specify and provide all components required to furnish and install a complete working furniture assembly as indicated in RFB. Dealer shall be responsible to order correct quantities of casegoods or systems furniture if handed components are used. Configurations must match A/E drawings exactly.

Dealer to brace, secure, stabilize furniture with appropriate hardware, cantilevers, panel connectors, stabilizing feet, etc. as required making product rigidity as substantial as necessary.

Dealer to provide concealed wire management under all tables, desks, returns, credenzas etc. Provide removable doors or panels in casegoods and conference tables for electrical and data access where required for access to outlets. Dealer shall coordinate with A/E drawings and General Contractor to verify all outlet and data locations and power source types. Dealer shall be responsible for coordination of any cable or wire management accessories required for power/ data connections to base building standards used on project.

Each workstation or individual office setting to be keyed differently. All locks within a workstation or office to be keyed alike. Dealer shall publish a floor plan that includes key numbers issued and marked on drawings as part of final issued installation documentation. Three (3) Master Keys per manufacturer shall be included by Dealer in the cost (if any) of the workstation and private office bid proposal.

Submittals such as shop drawings, samples, warranties, as-built drawings, etc., must be submitted timely so that job progress is not delayed. Dealer agrees that his shop drawings and submittals represent that he has determined all measurements, field construction criteria, and verified and coordinated each shop drawing and submittal with the requirements of the work and of the Furniture RFB. Approval of drawings or other submittals by the A/E or Project Manager shall not relieve Dealer of its obligation to perform the work in strict accordance with the Furniture RFB.

Please submit pricing per specifications under Furniture Quantity Schedule, total by line item, separate line item for total labor and lump sum for entire submittal. Provide turnkey solution with no hidden costs. Currently, the Town anticipates completed delivery and installation date in first week of February 2021.

ADDISON AIRPORT



CBP FACILITY

FURNITURE SPECIFICATIONS

ADDISON AIRPORT
FURNITURE QUANTITY SCHEDULE

9/21/2020

FURNITURE ITEM CODE	LEVEL	LEVEL	EXTENDED QUANTITY	MANUFACTURER	ITEM DESCRIPTION
	1	2			
WORKSTATIONS					
WS-01	0	1	1	OFS	CLUSTER OF 2 WORKSTATIONS
WS-02	0	1	1	OFS	CLUSTER OF 8 WORKSTATIONS
WS-03	0	1	1	OFS	CLUSTER OF 6 WORKSTATIONS
WS-04	0	1	1	OFS	CLUSTER OF 4 WORKSTATIONS
PRIVATE OFFICES					
PO-01	0	1	1	OFS	L-SHAPE OFFICE
PO-02	0	1	1	OFS	STRAIGHT SURFACE OFFICE
SEATING					
CH-01	5	17	22	OFS	ZONAL HIGH BACK
CH-02	0	6	6	OFS	PRET MID BACK TASK
CH-03	0	4	4	OFS	PRET MID BACK STOOL
CH-04	0	2	2	OFS	CINQUE 4 LEG
CH-05	0	6	6	OFS	AIRUS 4 LEG
CH-06	0	28	28	OFS	ACEN 4 LEG CASTOR
CH-07	0	16	16	PARCEL	OUTDOOR ARMCHAIR
CH-08	0	2	2	PARCEL	OUTDOOR BENCH
LOUNGE					
LO-01	11	0	11	OFS	SKARA MID BACK SWIVEL LOUNGECHAIR
LO-02	1	0	1	OFS	ANI SOFA, RIGHT TABLET/OUTLET
LO-03	1	0	1	OFS	ANI SOFA, LEFT TABLET/OUTLET
LO-04	1	0	1	OFS	ANI SOFA, LEFT TABLET/NO OUTLET
LO-05	1	0	1	OFS	ANI LOVESEAT, ARMLESS
LO-06	1	0	1	OFS	COACT LOVESEAT
LO-07	0	3	3	OFS	LONA LOUNGE CHAIR
LO-08	0	1	1	OFS	COSIMA SOFA
LO-09	0	1	1	OFS	ANI SOFA, ARMS
TABLES					
OT-01	2	0	2	OFS	DENRO END TABLE
OT-02	1	0	1	OFS	KOSA SIDE TABLE
OT-03	3	0	3	OFS	MAIVE COFFEE TABLE
OT-04	1	0	1	OFS	KOSA OVAL COFFEE TABLE
OT-05	0	3	3	OFS	WYRE END TABLE
OT-06	0	1	1	OFS	WYRE ROUND COFFEE TABLE
OT-07	0	1	1	OFS	KOSA SM OVAL COFFEE TABLE
OT-08	0	2	2	PARCEL	OUTDOOR SIDE TABLE
TB-01	0	14	14	OFS	APPLAUSE TRAINING TABLE
TB-02	0	1	1	OFS	HEYA DESK HEIGHT HUDDLE TABLE
TB-03	0	1	1	OFS	HEYA STANDING HEIGHT HUDDLE TABLE
TB-04	0	1	1	OFS	INTERMIX DESK HEIGHT TABLE
TB-05	0	3	3	OFS	APPLAUSE SOFT SQUARE TABLE
TB-06	0	3	3	PARCEL	OUTDOOR TABLE 72"
TB-07	0	1	1	PARCEL	OUTDOOR TABLE 96"
ACCESSORIES					
AC-01	10	3	13	OFS	18X18 THROW PILLOW
AC-02	2	20	22	SPACE CO	DUAL MONITOR ARM, CLAMP
AC-03	0	1	1	SPACE CO	SINGLE MONITOR ARM
AC-04	0	2	2	SPACE CO	DUAL MONITOR ARM, GROMMET
ST-01	1	0	1	OFS	STORAGE UNIT

ADDISON AIRPORT
FURNITURE PLAN

9/21/2020

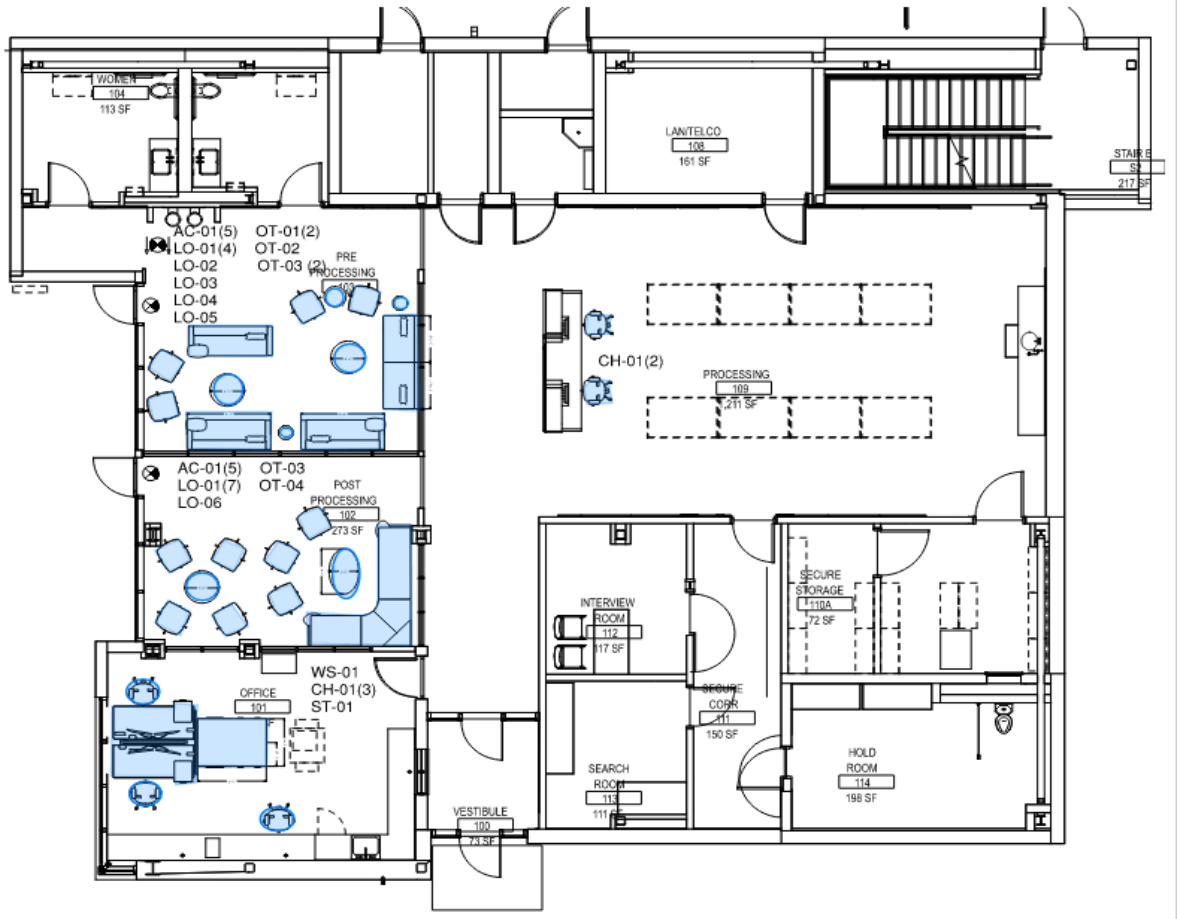

LEVEL 1

**ADDISON AIRPORT
FURNITURE PLAN**

9/21/2020

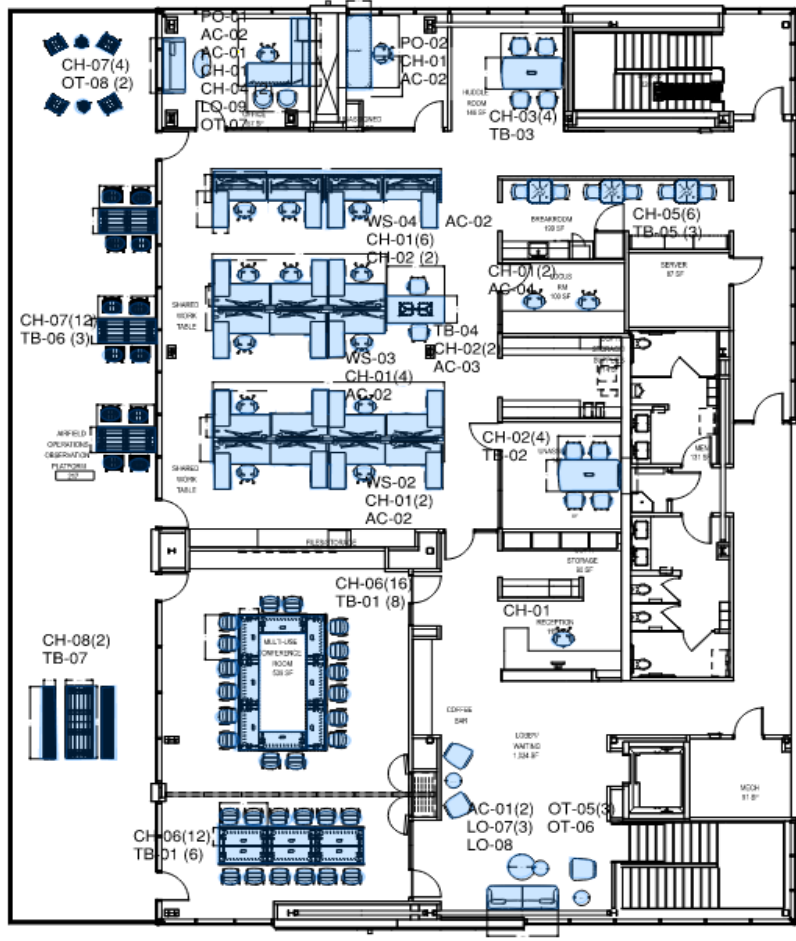

LEVEL 2

Furniture Specification

CH.01

Addison Airport -CBP Facility

Addison, TX

Job Number: 417151

Date Issued: 44095

Specification Type: No

Procurement Type: OMNIA

Item Information

Item Number CH.01
Type Task Chair

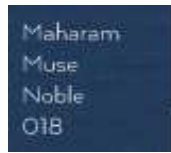

Seat Upholstery



Back Upholstery

Manufacturer: OFS
Product Name: Zonal
Product Number: 87017

Description High Back task chair, 2D arm, Lumbar, Standard Cylinder, Carpet Castor

Special Notes:
 GreenGuard

Dimensions:

Finishes:

Seat Upholstery Maharam
 Muse Noble 018

Back Upholstery Dove Mesh

Frame: Graphite
Base: Graphite
Casters: Black

Location

Room Number	Quantity	Room Name
109	2	PROCESSING
101	3	OFFICE
201	1	RECEPTION
208	12	OPEN WORK AREA
209	1	OFFICE
210	1	UNASSIGNED
206	2	FOCUS ROOM
	22	

Furniture Specification

CH.02

Addison Airport -CBP Facility

Addison, TX

Job Number: 417151

Date Issued: 44095

Specification Type: No

Procurement Type: OMNIA

Item Information

Item Number CH.02
Type Conference Chair



Seat Upholstery



Back Upholstery

Manufacturer: OFS
Product Name: Pret
Product Number: 86017

Description All Mesh, Fixed arm, carpet castor

Special Notes:
 GreenGuard

Dimensions:

Finishes:

Seat Upholstery Ocean Mesh

Back Upholstery N/A

Frame: Graphite
Base: Graphite
Casters: black

Location

<u>Room Number</u>	<u>Quantity</u>	<u>Room Name</u>
208	2	OPEN WORK AREA
204	4	UNASSIGNED
	6	

Furniture Specification

CH.03

Addison Airport -CBP Facility

Addison, TX

Job Number: 417151

Date Issued: 44095

Specification Type: No

Procurement Type: OMNIA

Item Information

Item Number

CH.03

Type

Conference Task Stool



Seat Upholstery



Shell Finish

Manufacturer: OFS

Product Name: Pret

Product Number: 86057

Description All Mesh, Fixed arm, carpet castor

Special Notes:
GreenGuard

Dimensions:

Finishes:

Seat Upholstery Ocean Mesh

Back Upholstery N/A

Frame: Graphite

Base: Graphite

Casters: black

Location

<u>Room Number</u>	<u>Quantity</u>	<u>Room Name</u>
211	4	HUDDLE

Furniture Specification

CH.04

Addison Airport -CBP Facility

Addison, TX

Job Number: 417151

Date Issued: 44095

Specification Type: No

Procurement Type: OMNIA

Item Information

Item Number CH.04
Type Sie Chair

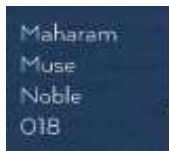

Seat Upholstery

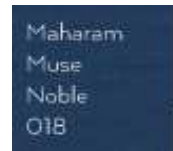

Back Upholstery

Manufacturer: OFS
Product Name: CINQUE
Product Number: 108037

Description Low back Guest Chair, fully upholstered, 4 legs with Felt Glide

Special Notes:
 GreenGuard

Dimensions: 24x25x29.75

Finishes:

Seat Upholstery Maharam
 Muse Noble 018

Back Upholstery Maharam
 Muse Noble 018

Frame: n/a
Base: Onyx
Casters: n/a

Location

Room Number	Quantity	Room Name
209	2	OFFICE

Furniture Specification

CH.05

Addison Airport -CBP Facility

Addison, TX

Job Number: 417151

Date Issued: 44095

Specification Type: No

Procurement Type: OMNIA

Item Information

Item Number CH.05
Type Side Chair

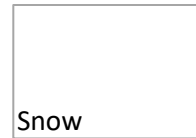

Shell

Manufacturer: OFS
Product Name: AIRUS SIDE
Product Number: 15123

Description Perforated Plastic Back, No arms

Special Notes: N/A
GreenGuard N/A

Dimensions: N/A

Finishes:

Seat Upholstery snow plastic

Back Upholstery snow plastic

Frame: silver
Base: glides
Casters: n/a

Location

<u>Room Number</u>	<u>Quantity</u>	<u>Room Name</u>
207	6	BREAKROOM

Furniture Specification

CH.06

Addison Airport -CBP Facility

Addison, TX

Job Number: 417151

Date Issued: 44095

Specification Type: No

Procurement Type: OMNIA

Item Information

Item Number CH.06
Type Conference Chair

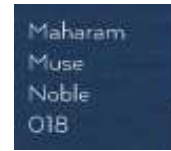

UPHOLSTERY

Manufacturer: OFS
Product Name: ACEN
Product Number: 50093

Description MESH BACK NESTING SIDE CHAIR, WITH ARMS

Special Notes: N/A
GreenGuard N/A

Dimensions:

Finishes:

Upholstery MAHARAM
 MUSE NOBLE 018

Frame: SILVER/ GREY
Base: N/A
Casters: BLACK CARPET

Location

<u>Room Number</u>	<u>Quantity</u>	<u>Room Name</u>
206	28	MULTIUSE CONFERENCE ROOM

Furniture Specification

CH.07

Addison Airport -CBP Facility

Addison, TX

Job Number: 417151

Date Issued: 44095

Specification Type: No

Procurement Type: OMNIA

Item Information

Item Number CH.07
Type OUTDOOR



FRAME



WOOD

Manufacturer: PARCEL
Product Name: ARM CHAIR
Product Number: A.ACH//

Description STEEL AND KNOT FREE SOUTHERN YELLOW PINE

Special Notes: N/A
GreenGuard N/A

Dimensions: 31X23X22

Finishes:

Upholstery N/A

WOOD: PARCEL CINNAMON
Frame: PARCEL YACHT ROCK BLUE
Base: N/A
Casters: N/A

Location

<u>Room Number</u>	<u>Quantity</u>	<u>Room Name</u>
217	16	OBSERVATION PLATFORM

Furniture Specification

CH.08

Addison Airport -CBP Facility

Addison, TX

Job Number: 417151

Date Issued: 44095

Specification Type: No

Procurement Type: OMNIA

Item Information

Item Number CH.08
Type OUTDOOR



FRAME



WOOD

Manufacturer: PARCEL
Product Name: BENCH
Product Number: A.BCH.96//

Description STEEL AND KNOT FREE SOUTHERN YELLOW PINE

Special Notes: N/A
GreenGuard N/A

Dimensions: 18X14X96

Finishes:

Upholstery N/A

WOOD: PARCEL CINNAMON
Frame: PARCEL YACHT ROCK BLUE
Base: N/A
Casters: N/A

Location

<u>Room Number</u>	<u>Quantity</u>	<u>Room Name</u>
217	2	OBSERVATION PLATFORM

Furniture Specification

AC.01

Addison Airport -CBP Facility

Addison, TX

Job Number: 417151

Date Issued: 44095

Specification Type: No

Procurement Type: OMNIA

Item Information

Item Number AC.01
Type PILLOW



Upholstery

Manufacturer: OFS
Product Name:
Product Number: TP-18X18

Description Throw Pillow, with insert, allergy free

Special Notes: N/A
GreenGuard N/A

Dimensions: 18x18

Finishes:

Upholstery Luna
 Tech Twist Connect

Frame: n/a
Base: n/a
Casters: n/a

Location

<u>Room Number</u>	<u>Quantity</u>	<u>Room Name</u>
103	5	PREPROCESSING
102	5	POSTPROCESSING
200	2	LOBBY WAITING
209	1	OFFICE
	13	

Furniture Specification

AC.02

Addison Airport -CBP Facility

Addison, TX

Job Number: 417151

Date Issued: 44095

Specification Type: No

Procurement Type: OMNIA

Item Information

Item Number AC.02
Type MONITOR ARM

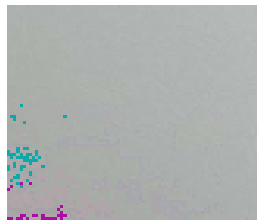
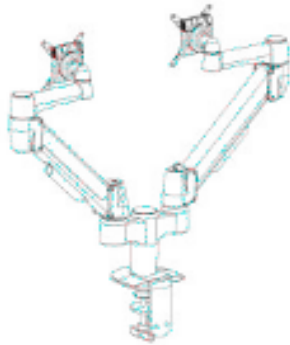

FRAME

Manufacturer: SPACECO
Product Name: SPACE ARM
Product Number: SA02QC-CL-PLT

Description DOUBLE QUICK CHANGE C-CLAMP LARGE

Special Notes: N/A
GreenGuard N/A

Dimensions: N/A

Finishes:

Upholstery N/A

Frame: PLATINUM
Base: N/A
Casters: N/A

Location

Room Number	Quantity	Room Name
101	2	OFFICE
208	18	OPEN WORK AREA
209	1	OFFICE
210	1	UNASSIGNED
	22	

Furniture Specification

AC.03

Addison Airport -CBP Facility

Addison, TX

Job Number: 417151

Date Issued: 44095

Specification Type: No

Procurement Type: OMNIA

Item Information

Item Number **AC.03**
Type MONITOR ARM

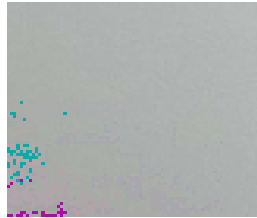
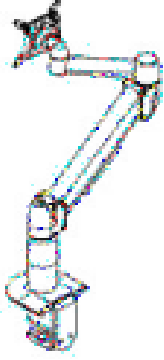

FRAME

Manufacturer: SPACECO
Product Name: SPACE ARM
Product Number: SA01QC-CL-PLT

Description SINGLE QUICK CONNECT C-CLAMP LARGE

Special Notes: N/A
GreenGuard N/A

Dimensions: N/A

Finishes:

Upholstery N/A

Frame: PLATINUM
Base: N/A
Casters: N/A

Location

<u>Room Number</u>	<u>Quantity</u>	<u>Room Name</u>
208	1	OPEN WORK AREA

Furniture Specification

AC.04

Addison Airport -CBP Facility

Addison, TX

Job Number: 417151

Date Issued: 44095

Specification Type: No

Procurement Type: OMNIA

Item Information

Item Number **AC.04**
Type MONITOR ARM

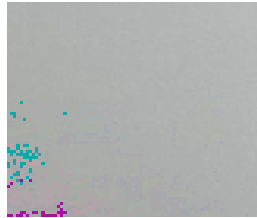
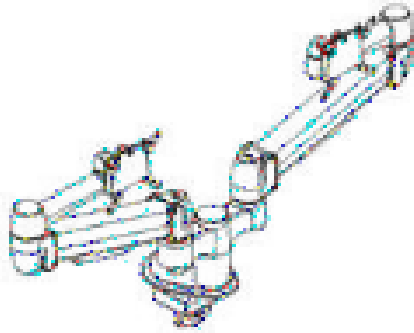

FRAME

Manufacturer: SPACECO
Product Name: SPACE ARM
Product Number: SA02QC-GT-PLT

Description DOUBLE QUICK CHANGE GROMMET MOUNT LARGE

Special Notes: N/A
GreenGuard N/A

Dimensions: N/A

Finishes:

Upholstery N/A

Frame: PLATINUM
Base: N/A
Casters: N/A

Location

<u>Room Number</u>	<u>Quantity</u>	<u>Room Name</u>
206	2	FOCUS ROOM

Addison Airport -CBP Facility

ST.01

Addison, TX

Job Number: 417151

Date Issued: 44095

Specification Type: No

Procurement Type: OMNIA

Item Information

Item Number **ST.01**
Type STORAGE UNIT

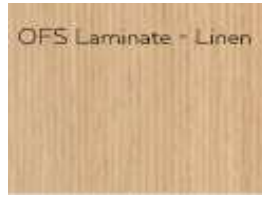

FINISH

Manufacturer: OFS
Product Name: INTERMIX
Product Number: CC-972527

Description SINGLE TOP SURFACE OVERALL DIMENSION 60X44 DOUBLE ENDED PEDESTALS 30X44
 PED 1- LATERAL FILE DRAWERS ON FRONT AND BACK; PED 2- TWO HINGED DOORS ON FRONT AND BACK (ONE INTERIOR ADJUSTABLE SHELF IN EACH); PARALLEL PULLS; LOCKING KEYED
Special Notes:
GreenGuard N/A

Dimensions: 60X44X44

Finishes:

Surface Finish LINEN
Top Finish LINEN
Notes PARALLEL STYLE PULL

Location

Room Number	Quantity	Room Name
101	1	OFFICE

Furniture Specification

LO.01

Addison Airport -CBP Facility

Addison, TX

Job Number: 417151

Date Issued: 44095

Specification Type: No

Procurement Type: OMNIA

Item Information

Item Number **LO.01**
Type LOUNGE CHAIR

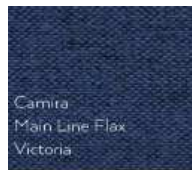

Upholstery

Manufacturer: OFS
Product Name: SKARA
Product Number: 205016

Description MID BACK SWIVEL LOUNGE CHAIR

Special Notes: N/A
GreenGuard N/A

Dimensions: 24.5X24.5X32

Finishes:

Upholstery CAMIRA
 MAIN LINE FLAX
 VICTORIA

Frame: n/a
Base: POLISHED ALUMINUM

Location

<u>Room Number</u>	<u>Quantity</u>	<u>Room Name</u>
103	4	PREPROCESSING
102	7	POSTPROCESSING
	11	

Furniture Specification

LO.02

Addison Airport -CBP Facility

Addison, TX

Job Number: 417151

Date Issued: 44095

Specification Type: No

Procurement Type: OMNIA

Item Information

Item Number **LO.02**

Type SOFA

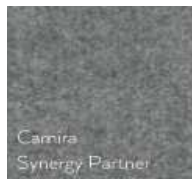

Upholstery

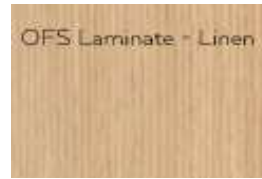

Manufacturer: OFS

Product Name: ANI SOFA

Product Number: 97043

Description HIGH LEG, ARM, RIGHT FACING TABLET, SILVER POWER AT BASE RIGHT FACING, METAL TUBE LEG

Special Notes: N/A

GreenGuard N/A

Dimensions: 73X28X30.5-32

Finishes:

Upholstery CAMIRA
SYNERGY PARTNER

Tablet 3D LAMINATE LINEN

Outlet Silver

Frame: n/a

Base: Onyx

Location

<u>Room Number</u>	<u>Quantity</u>	<u>Room Name</u>
103	1	PREPROCESSING

Furniture Specification

LO.03

Addison Airport -CBP Facility

Addison, TX

Job Number: 417151

Date Issued: 44095

Specification Type: No

Procurement Type: OMNIA

Item Information

Item Number **LO.03**

Type SOFA



Manufacturer: OFS
Product Name: ANI SOFA
Product Number: 97043

Description HIGH LEG, ARM, LEFT FACING TABLET, SILVER POWER AT BASE LEFT FACING, METAL TUBE LEG

Special Notes: N/A
GreenGuard N/A

Dimensions: 73X28X30.5-32

Finishes:

Upholstery CAMIRA
 SYNERGY PARTNER
Tablet 3D LAMINATE LINEN
Outlet Silver
Frame: n/a
Base: Onyx

Location

<u>Room Number</u>	<u>Quantity</u>	<u>Room Name</u>
103	1	PREPROCESSING

Furniture Specification

LO.04

Addison Airport -CBP Facility

Addison, TX

Job Number: 417151

Date Issued: 44095

Specification Type: No

Procurement Type: OMNIA

Item Information

Item Number **LO.04**
Type SOFA



Manufacturer: OFS
Product Name: ANI SOFA
Product Number: 97043

Description HIGH LEG, ARM, LEFT FACING TABLET, NO POWER , METAL TUBE LEG

Special Notes: N/A
GreenGuard N/A

Dimensions: 73X28X30.5-32

Finishes:

Upholstery CAMIRA
 SYNERGY PARTNER
Tablet 3D LAMINATE LINEN
Outlet Silver
Frame: n/a
Base: Onyx

Location

<u>Room Number</u>	<u>Quantity</u>	<u>Room Name</u>
103	1	PREPROCESSING

Furniture Specification

LO.05

Addison Airport -CBP Facility

Addison, TX

Job Number: 417151

Date Issued: 44095

Specification Type: No

Procurement Type: OMNIA

Item Information

Item Number **LO.05**
Type LOVESEAT



Upholstery

Manufacturer: OFS
Product Name: ANI LOVESEAT
Product Number: 97442

Description HIGH LEG, ARMLESS, NO TABLET, POWER LEFT FACING, METAL TUBE LEG

Special Notes: N/A
GreenGuard N/A

Dimensions: 86.50X28X30.5-32

Finishes:

Upholstery CAMIRA
 SYNERGY PARTNER
Tablet 3D LAMINATE LINEN
Outlet SILVER
Frame: n/a
Base: Onyx

Location

<u>Room Number</u>	<u>Quantity</u>	<u>Room Name</u>
103	1	PREPROCESSING

Furniture Specification

LO.06

Addison Airport -CBP Facility

Addison, TX

Job Number: 417151

Date Issued: 44095

Specification Type: No

Procurement Type: OMNIA

Item Information

Item Number **LO.06**
Type SECTIONAL



Manufacturer: OFS
Product Name: COACT
Product Number: F78042-MA; F78043-MA; F78045-M
Description MIDBACK, SINGLE LOW-ARM, RIGHT FACING TABLET, SILVER RIGHT FACING POWER, CORNER WITH BACK TABLE; LEFT FACING TABLET, SILVER LEFT FACING POWER, SQUARE METAL LEG
Special Notes: N/A
GreenGuard N/A
Dimensions: 84X84X28X30.5-32

Finishes:

Upholstery CAMIRA
 SYNERGY PARTNER
Tablet 3D LAMINATE LINEN
Outlet SILVER
Frame: n/a
Base: Onyx

Location

<u>Room Number</u>	<u>Quantity</u>	<u>Room Name</u>
102	1	POSTPROCESSING

Furniture Specification

LO.07

Addison Airport -CBP Facility

Addison, TX

Job Number: 417151

Date Issued: 44095

Specification Type: No

Procurement Type: OMNIA

Item Information

Item Number **LO.07**
Type LOUNGE CHAIR



Upholstery

Manufacturer: OFS
Product Name: LONA
Product Number: 84017

Description HIGHBACK SWIVEL WITH HEADREST

Special Notes: N/A
GreenGuard N/A

Dimensions: 29.5X32X38.5

Finishes:

Upholstery CAMIRA
 MAINLINE FLAX VICTORIA
Tablet N/A
Outlet N/A
Frame: n/a
Base: Onyx

Location

<u>Room Number</u>	<u>Quantity</u>	<u>Room Name</u>
200	3	LOBBY WAITING

Furniture Specification

LO.08

Addison Airport -CBP Facility

Addison, TX

Job Number: 417151

Date Issued: 44095

Specification Type: No

Procurement Type: OMNIA

Item Information

Item Number **LO.08**

Type SOFA



Upholstery

Manufacturer: OFS
Product Name: COSIMA
Product Number: 95043

Description SOFA

Special Notes: N/A
GreenGuard N/A

Dimensions: 89X31X31

Finishes:

Upholstery CAMIRA
 SYNERGY PARTNER
Tablet N/A
Outlet N/A
Frame: n/a
Base: VENEER LINEN

Location

<u>Room Number</u>	<u>Quantity</u>	<u>Room Name</u>
200	1	LOBBY WAITING

Furniture Specification

LO.09

Addison Airport -CBP Facility

Addison, TX

Job Number: 417151

Date Issued: 44095

Specification Type: No

Procurement Type: OMNIA

Item Information

Item Number **LO.09**

Type SOFA



Upholstery

Manufacturer: OFS
Product Name: ANI
Product Number: 97043

Description HIGH LEG, ARM, METAL TUBE LEG

Special Notes: N/A
GreenGuard N/A

Dimensions: 73X28X30.5

Finishes:

Upholstery CAMIRA
 SYNERGY PARTNER
Tablet N/A
Outlet N/A
Frame: n/a
Base: ONYX

Location

<u>Room Number</u>	<u>Quantity</u>	<u>Room Name</u>
209	1	OFFICE

Furniture Specification

Addison Airport -CBP Facility

Addison, TX

Job Number: 417151

Date Issued: 44095

Specification Type: No

Procurement Type: OMNIA

Item Information

Item Number **OT.01**
Type END TABLE



Manufacturer: OFS
Product Name: DENRO
Product Number: DNR-20ET

Description SOLID WOOD END TABLE, NON TORCHED

Special Notes: N/A
GreenGuard N/A

Dimensions: 20"H

Finishes:

Top N/A
Edge N/A
Base: WHITE OAK
Notes N/A

Location

<u>Room Number</u>	<u>Quantity</u>	<u>Room Name</u>
103	2	PREPROCESSING

Furniture Specification

Addison Airport -CBP Facility

Addison, TX

Job Number: 417151

Date Issued: 44095

Specification Type: No

Procurement Type: OMNIA

Item Information

Item Number OT.02
Type END TABLE

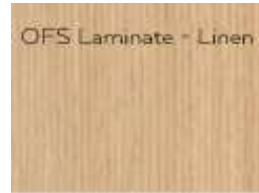

Manufacturer: OFS
Product Name: KOSA
Product Number: KS-19RD20H

Description ROUND END TABLE

Special Notes: N/A
GreenGuard N/A

Dimensions: 19X19X20

Finishes:

Top LAMINATE LINEN
Edge N/A
Base: ONYX
Notes N/A

Location

<u>Room Number</u>	<u>Quantity</u>	<u>Room Name</u>
103	1	PREPROCESSING

Furniture Specification

Addison Airport -CBP Facility

Addison, TX

Job Number: 417151

Date Issued: 44095

Specification Type: No

Procurement Type: OMNIA

Item Information

Item Number OT.03
Type COFFEE TABLE

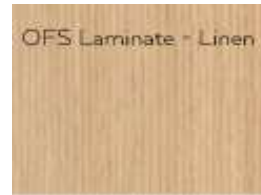
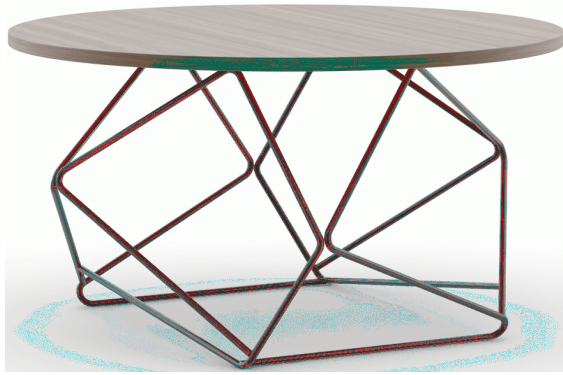

Manufacturer: OFS
Product Name: MAIVE
Product Number: MV-30R17H

Description COFFEE TABLE

Special Notes: N/A
GreenGuard N/A

Dimensions: 30X30X17

Finishes:

Top LAMINATE LINEN
Edge N/A
Base: ONYX
Notes N/A

Location

<u>Room Number</u>	<u>Quantity</u>	<u>Room Name</u>
103	2	PREPROCESSING
102	1	POSTPROCESSING
	3	

Furniture Specification

Addison Airport -CBP Facility

Addison, TX

Job Number: 417151

Date Issued: 44095

Specification Type: No

Procurement Type: OMNIA

Item Information

Item Number **OT.04**
Type COFFEE TABLE



Manufacturer: OFS
Product Name: KOSA
Product Number: KS-4226OV15H

Description OVAL COFFEE TABLE

Special Notes: N/A
GreenGuard N/A

Dimensions: 42X26X15

Finishes:

Top LAMINATE LINEN
Edge N/A
Base: ONYX
Notes N/A

Location

<u>Room Number</u>	<u>Quantity</u>	<u>Room Name</u>
102	1	POSTPROCESSING

Furniture Specification

Addison Airport -CBP Facility

Addison, TX

Job Number: 417151

Date Issued: 44095

Specification Type: No

Procurement Type: OMNIA

Item Information

Item Number OT.05
Type SIDE TABLE



Manufacturer: OFS
Product Name: WYRE
Product Number: WF-B20RD22H

Description BOTTLE FRAME ROUND END TABLE

Special Notes: N/A
GreenGuard N/A

Dimensions: 20X20X20

Finishes:

Top LAMINATE 3D FROSTY WHITE
Edge N/A
Base: ONYX
Notes N/A

Location

Room Number	Quantity	Room Name
200	3	LOBBY/ WAITING

Furniture Specification

OT.06

Addison Airport -CBP Facility

Addison, TX

Job Number: 417151

Date Issued: 44095

Specification Type: No

Procurement Type: OMNIA

Item Information

Item Number **OT.06**
Type COFFEE TABLE

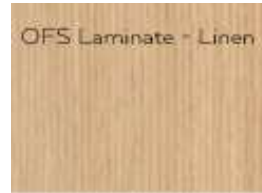

Manufacturer: OFS
Product Name: WYRE
Product Number: WF-T34RD17H

Description TRAPEZOID ROUND COFFEE TABLE

Special Notes: N/A
GreenGuard N/A

Dimensions: 34X34X17

Finishes:

Top LAMINATE 3D LINEN
Edge N/A
Base: ONYX
Notes N/A

Location

Room Number	Quantity	Room Name
200	1	LOBBY/WAITING

Furniture Specification

OT.07

Addison Airport -CBP Facility

Addison, TX

Job Number: 417151

Date Issued: 44095

Specification Type: No

Procurement Type: OMNIA

Item Information

Item Number **OT.07**
Type COFFEE TABLE

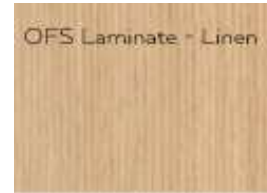

Manufacturer: OFS
Product Name: KOSA
Product Number: KS-3622OV15H

Description OVAL COFFEE TABLE

Special Notes: N/A
GreenGuard N/A

Dimensions: 36X22X15

Finishes:

Top LAMINATE LINEN
Edge N/A
Base: ONYX
Notes N/A

Location

Room Number	Quantity	Room Name
209	1	OFFICE

Furniture Specification

OT.08

Addison Airport -CBP Facility

Addison, TX

Job Number: 417151

Date Issued: 44095

Specification Type: No

Procurement Type: OMNIA

Item Information

Item Number

OT.08

Type

OCCATIONAL OUTDOOR TABLE



Manufacturer: PARCEL
Product Name: MILK STOOL TABLE
Product Number: A.MST//

Description STEEL AND KNOT FREE SOUTHERN YELLOW PINE

Special Notes: N/A
GreenGuard N/A

Dimensions: 18X14X14

Finishes:

Top PARCEL CINNAMON
Edge N/A
Base: PARCEL YACHT ROCK BLUE
Notes N/A

Location

<u>Room Number</u>	<u>Quantity</u>	<u>Room Name</u>
217	2	OBSERVATION PLATFORM

Furniture Specification

TB.01

Addison Airport -CBP Facility

Addison, TX

Job Number: 417151

Date Issued: 44095

Specification Type: No

Procurement Type: OMNIA

Item Information

Item Number **TB.01**
Type TRAINING

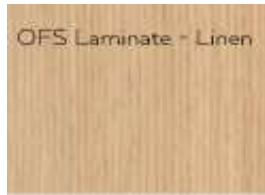

Top

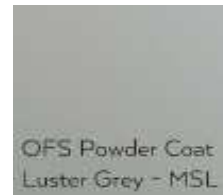

BASE

Manufacturer: OFS
Product Name: APPLAUSE
Product Number: A6024R-PWF3-CMCL-PS-84S-SCJ60-WM-V4
Description RECTANGULAR SURFACE, NO MODESTY, CENTER POWER LOCATION CUTOUT FOR PS-84S, CONNECTOR BRACKET EACH SIDE, DEUCE BASE CENTER FLIP AND NEST
Special Notes: SINGLE CIRCUIT POWER INFEED, (2) 15AMP OUTLETS AND (2) 2.1 AMP USB CHARGING PORTS PER TABLE, 1' POWER CORD WITH PERIMETER PLUG, SINGLE CIRCUIT JUMPER FOR DAISY CHAIN APPLICATION; CABLE MANAGEMENT FOR TABLE LEG AND UNDER SURFACE
GreenGuard N/A
Dimensions: 60X24

Finishes:

Top LINEN TFL LAMINATE
Edge SQUARE, MATCHING EDGE FINISH
Base: COLUMN AND FOOT LUSTER
Notes BLACK CASTOR FOR CARPET

Location

Room Number	Quantity	Room Name
203	14	MULTIUSE CONFERENCE

Furniture Specification

TB.02

Addison Airport -CBP Facility

Addison, TX

Job Number: 417151

Date Issued: 44095

Specification Type: No

Procurement Type: OMNIA

Item Information

Item Number **TB.02**
Type SEATED HEIGHT HUDDLE



Top

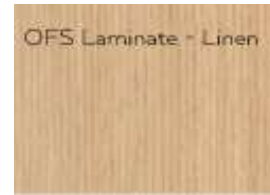

BASE

Manufacturer: OFS
Product Name: HEYA
Product Number: M82T-972519
Description SEATED HEIGHT WITH CENTER TABLE SURFACE CUTOUT FOR PS-80 POWER SUPPLY

Special Notes: POWER SUPPLY (2) 15AMP OUTLETS, (1) HDMI PORT, (1)USB PORT, WIRE MANAGEMENT BELOW SURFACE FROM POWER SUPPLY TO DRYWALL

GreenGuard N/A

Dimensions: 78X42X29

Finishes:

Top FROSTY WHITE LAMINATE
Edge TO MATCH SURFACE
Base: LINEN
Notes

Location

Room Number	Quantity	Room Name
204	1	UNASSIGNED

Furniture Specification

TB.03

Addison Airport -CBP Facility

Addison, TX

Job Number: 417151

Date Issued: 44095

Specification Type: No

Procurement Type: OMNIA

Item Information

Item Number **TB.03**
Type STANDING HEIGHT HUDDLE



Top

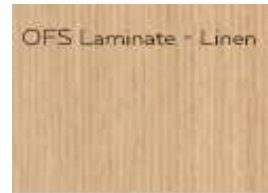

BASE

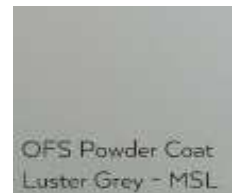

Manufacturer: OFS
Product Name: HEYA
Product Number: M82T-972518
Description STANDING HEIGHT WITH CENTER TABLE SURFACE CUTOUT FOR PS-80 POWER SUPPLY

Special Notes: POWER SUPPLY (2) 15AMP OUTLETS, (1) HDMI PORT, (1)USB PORT, WIRE MANAGEMENT BELOW SURFACE FROM POWER SUPPLY TO DRYWALL

GreenGuard N/A

Dimensions: 78X42X42

Finishes:

Top FROSTY WHITE LAMINATE
Edge TO MATCH SURFACE
Base: LINEN; KNUCKLE & FOOT RAIL LUSTER GREY
Notes

Location

Room Number	Quantity	Room Name
211	1	HUDDLE

Furniture Specification

TB.04

Addison Airport -CBP Facility

Addison, TX

Job Number: 417151

Date Issued: 44095

Specification Type: No

Procurement Type: OMNIA

Item Information

Item Number **TB.04**
Type SEATED HEIGHT HUDDLE

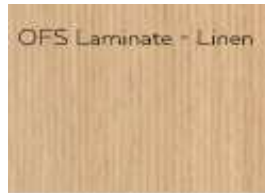

Top

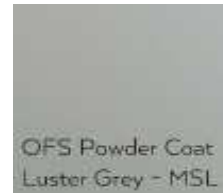

BASE

Manufacturer: OFS
Product Name: INTERMIX
Product Number: CC-P7236RT-ASK4218
Description SEATED HEIGHT WITH DUECE BASE

Special Notes: N/A

GreenGuard N/A

Dimensions: 72X36X29

Finishes:

Top LINEN
Edge SQUARE TO MATCH SURFACE
Base: LUSTER GREAY
Notes

Location

<u>Room Number</u>	<u>Quantity</u>	<u>Room Name</u>
208	1	OPEN WORK AREA

Furniture Specification

TB.05

Addison Airport -CBP Facility

Addison, TX

Job Number: 417151

Date Issued: 44095

Specification Type: No

Procurement Type: OMNIA

Item Information

Item Number **TB.05**
Type SEATED HEIGHT



Top



BASE

Manufacturer: OFS
Product Name: APPLAUSE
Product Number: A30SS
Description SEATED HEIGHT WITH DUECE STATIC X BASE

Special Notes: N/A

GreenGuard N/A

Dimensions: 30X30X29

Finishes:

Top FROSTY WHITE LAMINATE
Edge SQUARE TO MATCH SURFACE
Base: LUSTER GREAY
Notes STANDARD GLIDE

Location

Room Number	Quantity	Room Name
207	3	BREAKROOM

Furniture Specification

TB.06

Addison Airport -CBP Facility

Addison, TX

Job Number: 417151

Date Issued: 44095

Specification Type: No

Procurement Type: OMNIA

Item Information

Item Number **TB.06**
Type OUTDOOR TABLE



Manufacturer: PARCEL
Product Name: DINING HEIGHT TABLE (SMALL)
Product Number: A.TB3.72//

Description STEEL AND KNOT FREE SOUTHERN YELLOW PINE

Special Notes: N/A
GreenGuard N/A

Dimensions: 30X34X72

Finishes:

Top PARCEL CINNAMON
Edge N/A
Base: PARCEL YACHT ROCK BLUE
Notes N/A

Location

<u>Room Number</u>	<u>Quantity</u>	<u>Room Name</u>
217	3	OBSERVATIONAL PLATFORM

Furniture Specification

TB.07

Addison Airport -CBP Facility

Addison, TX

Job Number: 417151

Date Issued: 44095

Specification Type: No

Procurement Type: OMNIA

Item Information

Item Number **TB.07**
Type OUTDOOR TABLE



Manufacturer: PARCEL
Product Name: DINING HEIGHT TABLE (LARGE)
Product Number: A.TB3.96//

Description STEEL AND KNOT FREE SOUTHERN YELLOW PINE

Special Notes: N/A
GreenGuard N/A

Dimensions: 30X34X96

Finishes:

Top PARCEL CINNAMON
Edge N/A
Base: PARCEL YACHT ROCK BLUE
Notes N/A

Location

<u>Room Number</u>	<u>Quantity</u>	<u>Room Name</u>
217	1	OBSERVATIONAL PLATFORM

Furniture Specification

PO.01

Addison Airport -CBP Facility

Addison, TX

Job Number: 417151
Date Issued: 44095
Specification Type: No
Procurement Type: OMNIA

Item Information

Item Number PO.01
Type OFFICE

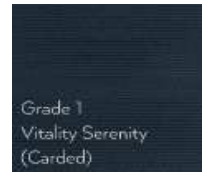
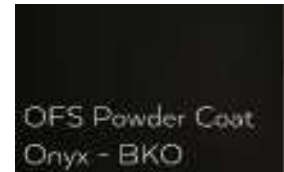

Manufacturer: OFS
Product Name: STAKS
Product Number: DEALER TO REFFERENCE FULL BOM FROM MANUFACTURER

Description 30"W WALL MOUNT ORGANIZER WITH HINGED DOOR; 60"W WALL MOUNT SHELF; 18"W WALL MOUNT TACKBOARD WITH ROUNDED CORNERS; 30"D X 78"W HEIGHT ADJUSTABLE DESK WITH MODESTY PANEL; 22"D X 90"W LOW HEIGHT CREDENZA WITH (QTY 2) 30"W OPEN SHELVING & 30"W BOX/FILE LOCKING; CLAMP ON CONVIENCE POWER (POWER/USB); POWER STRIP AND WIRE MANAGER BELOW SURFACE

Special Specification Notes: N/A

GreenGuard N/A

Dimensions: SEE ABOVE

Finishes:

Storage Surface LAMINATE LINEN
Storage Top LAMINATE LINEN
Finish Notes TACK BOARD VITALITY SERENITY
Table Top LAMINATE LINEN
Table Edge TO MATCH SURFACE
Table Finish Notes ONYX BASE; HEIGHT ADJUSTABLE
Notes: PARALLEL PULL IN ONYX

Location

Room Number	Quantity	Room Name
209	1	OFFICE

Furniture Specification

PO.02

Addison Airport -CBP Facility

Addison, TX

Job Number: 417151

Date Issued: 44095

Specification Type: No

Procurement Type: OMNIA

Item Information

Item Number **PO.02**

Type OFFICE



Manufacturer: OFS
Product Name: STAKS
Product Number: DEALER TO REFERENCE FULL BOM FROM MANUFACTURER

Description 30"D DESK WITH METAL REESE BASES; T-BASE CENTER SUPPORT; CLAMP CONVICIENCE POWER (POWER/USB)

Special Specification Notes: N/A

GreenGuard N/A

Dimensions: SEE ABOVE

Finishes:

Storage Surface LAMINATE LINEN
Storage Top LAMINATE LINEN
Finish Notes N/A
Table Top LAMINATE LINEN
Table Edge TO MATCH SURFACE
Table Finish Notes ONYX BASE
Notes: N/A

Location

Room Number	Quantity	Room Name
210	1	UNASSIGNED

Furniture Specification

WS.01

Addison Airport -CBP Facility

Addison, TX

Job Number: 417151

Date Issued: 44095

Specification Type: No

Procurement Type: OMNIA

Item Information

Item Number **WS.01**
Type WORKSTATION

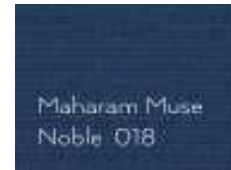

Manufacturer: OFS
Product Name: RANGE
Product Number: DEALER TO REFERENCE FULL BOM FROM MANUFACTURER

Description DUAL SIDED BENCH; HEIGHT ADJUSTABLE BENCHING UNIT; 48"H END PRIVACY PANEL WITH SQUARE CORNERS; CLAMP CONVIENCE POWER (POWER/USB); CENTER MOUNT TACKBOARD WITH ROUNDED CORNERS; MOBILE PEDESTAL WITH SHELF & FILE DRAWER BEHIND DRAWER FRONT; CUSHION TOP; LOCKING; 2 DUPLEXES PER USER; ON HARD WIRED INFEED; WIRE MANAGEMENT BELOW SURFACE

GreenGuard N/A

Dimensions: N/A

Finishes:

Top/ STORAGE/ END PANEL LAMINATE LINEN
Edge TO MATCH SURFACE
Base: ONYX
Notes TACKBOARD ENCORE SILVER
 PEDESTAL CUSHION TOP MAHRAM MUSE NOBLE 018

Location

Room Number	Quantity	Room Name
101	1	OFFICE

Furniture Specification

WS.02

Addison Airport -CBP Facility

Addison, TX

Job Number: 417151
Date Issued: 44095
Specification Type: No
Procurement Type: OMNIA

Item Information

Item Number **WS.02**
Type WORKSTATION



Manufacturer: OFS
Product Name: RANGE
Product Number: DEALER TO REFERENCE FULL BOM FROM MANUFACTURER
REFER TO PLAN FOR ACTUAL PEDESTAL LOCATIONS

Description DUAL SIDED BENCH; HEIGHT ADJUSTABLE BENCHING UNIT; 48"H END PRIVACY PANEL WITH SQUARE CORNERS; CLAMP CONVIENENCE POWER (POWER/USB); CENTER MOUNT TACKBOARD WITH ROUNDED CORNERS; LOW HEIGHT 48"W CREDENZA WITH 18"W OPEN STORAGE & 30"W BOX/FILE WITH FELT TOP & SQUARE METAL BASES; LOCKING; 2 DUPLEXES PER USER; ON HARD WIRED INFEEED; WIRE MANAGEMENT BELOW SURFACE

GreenGuard N/A

Dimensions: N/A

Finishes:

Top/ STORAGE/ END PANEL LAMINATE LINEN
Edge TO MATCH SURFACE
Base: ONYX
Notes TACKBOARD ENCORE SILVER
 CREDENZA TOP GREY FELT

Location

<u>Room Number</u>	<u>Quantity</u>	<u>Room Name</u>
208	1	OPEN WORK AREA

Furniture Specification

WS.03

Addison Airport -CBP Facility

Addison, TX

Job Number: 417151

Date Issued: 44095

Specification Type: No

Procurement Type: OMNIA

Item Information

Item Number **WS.03**
Type WORKSTATION



Manufacturer: OFS
Product Name: RANGE
Product Number: DEALER TO REFERENCE FULL BOM FROM MANUFACTURER
REFER TO PLAN FOR ACTUAL PEDESTAL LOCATIONS

Description DUAL SIDED BENCH; HEIGHT ADJUSTABLE BENCHING UNIT; 48"H END PRIVACY PANEL WITH SQUARE CORNERS; CLAMP CONVIENCE POWER (POWER/USB); CENTER MOUNT TACKBOARD WITH ROUNDED CORNERS; LOW HEIGHT 48"W CREDENZA WITH 18"W OPEN STORAGE & 30"W BOX/FILE WITH FELT TOP & SQUARE METAL BASES; LOCKING; 2 DUPLEXES PER USER; ON HARD WIRED INFEEED; WIRE MANAGEMENT BELOW SURFACE

GreenGuard N/A

Dimensions: N/A

Finishes:

Top/ STORAGE/ END PANEL LAMINATE LINEN
Edge TO MATCH SURFACE
Base: ONYX
Notes TACKBOARD ENCORE SILVER
 CREDENZA TOP GREY FELT

Location

<u>Room Number</u>	<u>Quantity</u>	<u>Room Name</u>
208	1	OPEN WORK AREA

Furniture Specification

WS.04

Addison Airport -CBP Facility

Addison, TX

Job Number: 417151

Date Issued: 44095

Specification Type: No

Procurement Type: OMNIA

Item Information

Item Number **WS.04**
Type WORKSTATION



Manufacturer: OFS
Product Name: STACKS
Product Number: DEALER TO REFERENCE FULL BOM FROM MANUFACTURER
REFER TO PLAN FOR ACTUAL PEDESTAL LOCATIONS

Description SINGLE SIDED BENCH; HEIGHT ADJUSTABLE BENCHING UNIT; 48"H END PRIVACY PANEL WITH SQUARE CORNERS; 33"H PANELS INTERMEDIATE FOR SUPPORT CLAMP CONVIENENCE POWER (POWER/USB); CENTER MOUNT TACKBOARD WITH ROUNDED CORNERS; LOW HEIGHT 48"W CREDENZA WITH 18"W OPEN STORAGE & 30"W BOX/FILE WITH FELT TOP & SQUARE METAL BASES; LOCKING; 2 DUPLEXES PER USER; ON HARD WIRED INFEEED; WIRE MANAGEMENT BELOW SURFACE

GreenGuard N/A

Dimensions: N/A

Finishes:

Top/ STORAGE/ END PANEL LAMINATE LINEN
Edge TO MATCH SURFACE
Base: ONYX
Notes TACKBOARD ENCORE SILVER
 CREDENZA TOP GREY FELT

Location

<u>Room Number</u>	<u>Quantity</u>	<u>Room Name</u>
208	1	OPEN WORK AREA

TOWN OF ADDISON, TEXAS
CONTRACTOR INSURANCE REQUIREMENTS & AGREEMENT

REQUIREMENTS

Contractors performing work on TOWN OF ADDISON property or public right-of-way shall provide the TOWN OF ADDISON a certificate of insurance or a copy of their insurance policy(s) (and including a copy of the endorsements necessary to meet the requirements and instructions contained herein) evidencing the coverages and coverage provisions identified herein within ten (10) days of request from TOWN OF ADDISON. Contractors shall provide TOWN OF ADDISON evidence that all subcontractors performing work on the project have the same types and amounts of coverages as required herein or that the subcontractors are included under the contractor's policy. Work shall not commence until insurance has been approved by TOWN OF ADDISON.

All insurance companies and coverages must be authorized by the Texas Department of Insurance to transact business in the State of Texas and must have a A.M. Best's rating A-:VII or greater.

Listed below are the types and minimum amounts of insurances required and which must be maintained during the term of the contract. TOWN OF ADDISON reserves the right to amend or require additional types and amounts of coverages or provisions depending on the nature of the work.

TYPE OF INSURANCE	AMOUNT OF INSURANCE	PROVISIONS
1. Workers' Compensation Employers' Liability to include: (a) each accident (b) Disease Policy Limits (c) Disease each employee	Statutory Limits per occurrence Each accident \$1,000,000 Disease Policy Limits \$1,000,000 Disease each employee \$1,000,000	<u>TOWN OF ADDISON to be provided a WAIVER OF SUBROGATION AND 30 DAY NOTICE OF CANCELLATION</u> or material change in coverage. Insurance company must be A-:VII rated or above.
2. Commercial (Public) General Liability to include coverage for: a) Bodily Injury b) Property damage c) Independent Contractors d) Personal Injury e) Contractual Liability	Bodily Injury/Property Damage per occurrence \$1,000,000, General Aggregate \$2,000,000 Products/Completed Aggregate \$2,000,000, Personal Advertising Injury per occurrence \$1,000,000, Medical Expense 5,000	<u>TOWN OF ADDISON to be listed as ADDITIONAL INSURED and provided 30 DAY NOTICE OF CANCELLATION</u> or material change in coverage. Insurance company must be A-:VII rated or above.
3. Business Auto Liability to include coverage for: a) Owned/Leased vehicles b) Non-owned vehicles c) Hired vehicles	Combined Single Limit \$1,000,000	<u>TOWN OF ADDISON to be listed as ADDITIONAL INSURED and provided 30 DAY NOTICE OF CANCELLATION</u> or material change in coverage. Insurance company must be A-:VII-rated or above.

Certificate of Liability Insurance forms (together with the endorsements necessary to meet the requirements and instructions contained herein) may be **faxed** to the Purchasing Department: **972-450-7074** or **emailed to: purchasing@addisontx.gov**. Questions regarding required insurance should be directed to the Purchasing Manager.

With respect to the foregoing insurance,

- All liability policies shall contain no cross liability exclusions or insured versus insured restrictions applicable to the claims of the Town of Addison.

- 2. All insurance policies shall be endorsed to require the insurer to immediately notify the Town of Addison, Texas of any material change in the insurance coverage.
- 3. All insurance policies shall be endorsed to the effect that the Town of Addison, Texas will receive at least thirty (30) days' notice prior to cancellation or non-renewal of the insurance.
- 4. All insurance policies, which name the Town of Addison, Texas as an additional insured, must be endorsed to read as primary coverage regardless of the application of other insurance.
- 5. Insurance must be purchased from insurers that are financially acceptable to the Town of Addison and licensed to do business in the State of Texas.

All insurance must be written on forms filed with and approved by the Texas Department of Insurance. Upon request, Contractor shall furnish the Town of Addison with complete copies of all insurance policies certified to be true and correct by the insurance carrier.

This form must be signed and returned with your quotation. You are stating that you do have the required insurance and if selected to perform work for TOWN OF ADDISON, will provide the certificates of insurance (and endorsements) with the above requirements to TOWN OF ADDISON within 10 working days.

A CONTRACT/PURCHASE ORDER WILL NOT BE ISSUED WITHOUT EVIDENCE AND APPROVAL OF INSURANCE.

AGREEMENT

I agree to provide the above described insurance coverages within 10 working days if selected to perform work for TOWN OF ADDISON. I also agree to require any subcontractor(s) to maintain insurance coverage equal to that required by the Contractor. It is the responsibility of the Contractor to assure compliance with this provision. The TOWN accepts no responsibility arising from the conduct, or lack of conduct, of the Subcontractor.

Project/Bid# Solicitation #2020-231 CBP Facility Furniture & Installation Services

Company: bkm Total Office of Texas, LLC

Printed Name: Steve Burak

Signature: _____ **Date:** 09/30/2020

Town of Addison

Indemnification Agreement

Contractor's Indemnity Obligation. Contractor covenants, agrees to, and shall DEFEND (with counsel reasonably acceptable to Owner), INDEMNIFY, AND HOLD HARMLESS Owner, its past, present and future elected and appointed officials, and its past, present and future officers, employees, representatives, and volunteers, individually or collectively, in both their official and private capacities (collectively, the "Owner Persons" and each being an "Owner Person"), from and against any and all claims, liabilities, judgments, lawsuits, demands, harm, losses, damages, proceedings, suits, actions, causes of action, liens, fees (including attorney's fees), fines, penalties, expenses, or costs, of any kind and nature whatsoever, made upon or incurred by Owner and/or Owner Person, whether directly or indirectly, (the "Claims"), that arise out of, result from, or relate to: (i) the services to be provided by Contractor pursuant to this Agreement, (ii) any representations and/or warranties by Contractor under this Agreement, (iii) any personal injuries (including but not limited to death) to any Contractor Persons (as hereinafter defined) and any third persons or parties, and/or (iv) any act or omission under, in performance of, or in connection with this Agreement by Contractor or by any of its owners, directors, officers, managers, partners, employees, agents, contractors, subcontractors, invitees, patrons, guests, customers, licensees, sublicensees, or any other person or entity for whom Contractor is legally responsible, and their respective owners, directors, officers, directors, officers, managers, partners, employees, agents, contractors, subcontractors, invitees, patrons, guests, customers, licensees, sublicensees (collectively, "Contractor Persons"). SUCH DEFENSE, INDEMNITY AND HOLD HARMLESS SHALL AND DOES INCLUDE CLAIMS ALLEGED OR FOUND TO HAVE BEEN CAUSED IN WHOLE OR IN PART BY THE NEGLIGENCE OR GROSS NEGLIGENCE OF OWNER OR ANY OTHER OWNER PERSON, OR CONDUCT BY OWNER OR ANY OTHER OWNER PERSON THAT WOULD GIVE RISE TO STRICT LIABILITY OF ANY KIND.

Contractor shall promptly advise Owner in writing of any claim or demand against any Owner Person related to or arising out of Contractor's activities under this Agreement and shall see to the investigation and defense of such claim or demand at Contractor's sole cost and expense. The Owner Persons shall have the right, at the Owner Persons' option and own expense, to participate in such defense without relieving Contractor of any of its obligations hereunder. This defense, indemnity, and hold harmless provision shall survive the termination or expiration of this Agreement.

The provisions in the foregoing defense, indemnity and hold harmless are severable, and if any portion, sentence, phrase, clause or word included therein shall for any reason be held by a court of competent jurisdiction to be invalid, illegal, void, or unenforceable in any respect, such invalidity, illegality, voidness, or unenforceability shall not affect any other provision thereof, and this defense, indemnity and hold harmless provision shall be considered as if such invalid, illegal, void, or unenforceable provision had never been contained in this Agreement. **In that regard, if the capitalized language included in the foregoing indemnity is so determined to be void or unenforceable, the parties agree that:**

(i) the foregoing defense, indemnity, and hold harmless obligation of Contractor shall be to the extent Claims are caused by, arise out of, or result from, in whole or in part, any act or omission of Contractor or any Contractor Persons; and

(ii) notwithstanding the provisions of the foregoing subparagraph (i), to the fullest extent permitted by law, Contractor shall INDEMNIFY, HOLD HARMLESS, and DEFEND Owner and Owner Persons from and against all Claims arising out of or resulting from bodily injury to, or sickness, disease or death of, any employee, agent or representative of Contractor or any of its subcontractors, regardless of whether such Claims are caused, or are alleged to be caused, in whole or in part, by the negligence, or any act or omission, of Owner or any Owner Persons, it being the expressed intent of Owner and Contractor that IN SUCH EVENT THE CONTRACTOR'S INDEMNITY, HOLD HARMLESS, AND DEFENSE OBLIGATION SHALL AND DOES INCLUDE CLAIMS ALLEGED OR FOUND TO HAVE BEEN CAUSED IN WHOLE OR IN PART BY THE NEGLIGENCE OR GROSS NEGLIGENCE OF OWNER OR ANY OTHER OWNER PERSON, OR CONDUCT BY OWNER OR ANY OTHER OWNER PERSON THAT WOULD GIVE RISE TO STRICT LIABILITY OF ANY KIND. The indemnity obligation under this subparagraph (ii) shall not be limited by any limitation on the amount or type of damages, compensation, or benefits payable by or for Contractor under workers compensation acts, disability benefit acts, or other employee benefit acts.

I understand that the indemnification provisions are required of all Town of Addison Contracts. I have read the provisions and agree to the terms of these provisions.

Project/Bid#: Solicitation #2020-231 Addison Airport CBP Facility Furniture & Installation Services

Company Name: BKM Total Office of Texas

Signature:

Date:



Interested Parties

In 2015, the Texas Legislature adopted [House Bill 1295](#), which added section 2252.908 of the Government Code. The law states that a governmental entity or state agency may not enter into certain contracts with a business entity unless the business entity submits a disclosure of interested parties to the governmental entity or state agency at the time the business entity submits the signed contract to the governmental entity or state agency. The law applies only to a contract of a governmental entity or state agency that either (1) requires an action or vote by the governing body of the entity or agency before the contract may be signed or (2) has a value of at least \$1 million. The disclosure requirement applies to a contract entered into on or after January 1, 2016.

The Texas Ethics Commission was required to adopt rules necessary to implement that law, prescribe the disclosure of interested parties form, and post a copy of the form on the commission's website. The commission adopted the Certificate of Interested Parties form (Form 1295) on October 5, 2015. The commission also adopted new rules (Chapter 46) on November 30, 2015, to implement the law.

Filing Process

On January 1, 2016, the commission made available on its website a new filing application that must be used to file Form 1295. A business entity must use the application to enter the required information on Form 1295 and print a copy of the completed form, which will include a certification of filing that will contain a unique certification number. An authorized agent of the business entity must sign the printed copy of the form and have the form notarized. The completed Form 1295 with the certification of filing must be filed with the governmental body or state agency with which the business entity is entering into the contract.

The governmental entity or state agency must notify the commission, using the commission's filing application, of the receipt of the filed Form 1295 with the certification of filing not later than the 30th day after the date the contract binds all parties to the contract. The commission will post the completed Form 1295 to its website within seven business days after receiving notice from the governmental entity or state agency.

Information regarding how to use the filing application will be available on this site by January 1, 2016. https://www.ethics.state.tx.us/whatsnew/elf_info_form1295.htm, please follow Instructional Video for Business Entities.

Town of Addison

REQUEST FOR PROPOSAL TERMS AND CONDITIONS

1. **APPLICABILITY:** These standard Terms and Conditions and the Terms and Conditions, Specifications, Drawings and other requirements included in the Town of Addison's Request for Proposal (collectively, "Terms and Conditions") are applicable to Contracts/Purchase Orders issued by the Town of Addison (hereinafter referred to as the "Town" or "Buyer") and the Seller (herein after referred to as the "Seller," "Proposer," "Contractor," or "Supplier"). Any deviations must be in writing and signed by a representative of the Town's Purchasing Department and the Supplier. No Terms and Conditions contained in the Seller's Proposal, Invoice or Statement shall serve to modify the terms set forth herein. If there is a conflict between the Terms and Conditions and the provisions on the face of the Contract/Purchase Order, the Terms and Conditions will take precedence and control.
2. **OFFICIAL PROPOSAL NOTIFICATION:** The Town utilizes the following for official notifications of proposal opportunities: www.bidsync.com and the Dallas Morning News of Dallas County. These are the only forms of notification authorized by the Town. The Town is not responsible for receipt of notifications or information from any source other than those listed. It shall be the Supplier's responsibility to verify the validity of all Request for Proposal information received from any source other than the Town. There will be NO COST to the Seller for using BidSync for its Bids/Proposals.
3. **PRIOR OR PENDING LITIGATION OR LAW SUITS:** Each Proposer must include in its proposal a complete disclosure of any alleged significant prior or ongoing contract failures, any civil or criminal litigation or investigation pending which involves the Proposer or in which the Proposer has been judged guilty or liable.
4. **COST OF RESPONSE:** Any cost incurred by the Supplier in responding to the Request for Proposal is the responsibility of the supplier and cannot be charged to the Town.
5. **PROHIBITION AGAINST PERSONAL INTEREST IN CONTRACTS:** No Town of Addison employee shall have a direct or indirect financial interest in any contract with the Town, or be directly or indirectly financially interested in the sale of land, materials, supplies or services to the Town.
6. **COMPETITIVE PRICING:** It is the intent of the Town to consider Interlocal Cooperative Agreements and State/Federal contracts in determining the best value for the Town.
7. **INTERLOCAL AGREEMENT:** The successful Proposer agrees to extend prices to all entities that have entered into or will enter into joint purchasing interlocal cooperation agreements with the Town. The Town is a participating member of several interlocal cooperative purchasing agreements. As such, the Town has executed interlocal agreements, as permitted under Chapter 791 of the Texas Government Code, with certain other political subdivisions, authorizing participation in a cooperative purchasing program. The successful Supplier may be asked to provide products/services based upon terms and conditions of award, to any other participant in a cooperative purchasing program.
8. **CORRESPONDENCE:** The proposal number must appear on all correspondence and inquiries pertaining to the Request for Proposal. The Purchase Order number must appear on all invoices or other correspondence relating to the contract.
9. **INDEMNITY/INSURANCE:** See attached Town of Addison minimum requirements.
10. **ERROR-QUANTITY:** Proposals must be submitted in units of quantity specified, extended, and totaled. In the event of discrepancies in extension, the unit prices shall govern.
11. **ACCEPTANCE:** The right is reserved to accept or reject all or part of the proposal or offer, and to accept the proposal or offer considered most advantageous to the Town by line item or total offer or proposal.
12. **PROPOSAL LIST REMOVAL:** The Town reserves the right to remove a Supplier from any Proposal list for: (1) continued failure to be responsive to the Town, (2) failure to deliver merchandise within promised time, (3) delivery of substandard merchandise, or (4) failure to comply with the Contract/Purchase Order requirements.
13. **CONTRACT RENEWAL OPTIONS:** In the event a clause for option to renew for an additional period is included in the Request for Proposal, all renewals will be based solely upon the option and agreement between the Town and the Supplier. Either party dissenting will terminate the contract in accordance with its initial specified term.
14. **TAXES-EXEMPTION:** All quotations are required to be submitted LESS Federal Excise and State Sales Taxes. Tax Exemption Certificate will be executed for the successful Supplier.
15. **ASSIGNMENT AND SUCCESSORS:** The successful Supplier shall not assign, transfer, pledge, subcontract, or otherwise convey, in any manner whatsoever, any contract resulting from this proposal, in whole or in part, without the prior written consent of the Town of Addison.
16. **INVOICING:** Send ORIGINAL INVOICE to address indicated on the contract/purchase order. If invoice is subject to cash discounts the discount period will begin on the day invoices are received. So that proper cash discount may be computed, invoice should show amount of freight as a separate item, if applicable; otherwise, cash discount will be computed on total amount of invoice.

17. ELECTRONIC SIGNATURE – UNIFORM ELECTRONIC TRANSACTION ACT: The Town adopts Texas Business and Commerce Code Chapter 322, Uniform Electronic Transactions Act, allowing individuals, companies, and governmental entities to lawfully use and rely on electronic signatures.

18. FUNDING OUT CLAUSE: This agreement or contract may be terminated by the Town without notice and without penalty or liability in the event that (1) the Town lacks sufficient funds for this agreement or contract; (2) funds for this agreement or contract are not appropriated by the Town Council of the Town; and (3) funds for this agreement or contract that are or were to be provided by grant or through an outside service are withheld, denied or are otherwise not available to the Town.

19. DISPUTE RESOLUTION: Pursuant to subchapter I, Chapter 271, TEXAS LOCAL GOVERNMENT CODE, Contractor agrees that, prior to instituting any lawsuit or other proceeding arising from any dispute or claim of breach under this Agreement (a "Claim"), the parties will first attempt to resolve the Claim by taking the following steps: (i) A written notice substantially describing the factual and legal basis of the Claim shall be delivered by the Contractor to the Town within one-hundred eighty (180) days after the date of the event giving rise to the Claim, which notice shall request a written response to be delivered to the Contractor not less than fourteen (14) business days after receipt of the notice of Claim; (ii) if the response does not resolve the Claim, in the opinion of the Contractor, the Contractor shall give notice to that effect to the Town whereupon each party shall appoint a person having authority over the activities of the respective parties who shall promptly meet, in person, in an effort to resolve the Claim; (iii) if those persons cannot or do not resolve the Claim, then the parties shall each appoint a person from the highest tier of managerial responsibility within each respective party, who shall then promptly meet, in person, in an effort to resolve the Claim.

20. DISCLOSURE OF CERTAIN RELATIONSHIPS: Chapter 176 of the Texas Local Government Code requires that any person, as defined in the statute, considering doing business with a local government entity disclose in the Questionnaire Form CIQ, the supplier or person's affiliation or business relationship that might cause a conflict of interest with a local government entity. By law, this questionnaire must be filed with the Records Administrator of the Town not later than the 7th business day after the later of (a) the date the person (i) begins discussions or negotiations to enter into a contract with the local governmental entity, or (b) submits to the local governmental entity an application, response to a request for proposals or bids, correspondence, or another writing related to a potential contract with the local governmental entity, or (b) the date the person becomes aware (i) of an employment or other business relationship with a local government officer, or a family member of the officer, described by the statute, or (ii) that the person has given one or more gifts described in the statute. See Section 176.006, Local Government Code. A person commits an offense if the person violates Section 176.006, Local Government Code. An offense under this section is a Class C misdemeanor. The questionnaire may be found at www.ethics.state.tx.us/forms/CIQ.pdf. By submitting a response to this request, Supplier represents that it is in compliance with the requirements of Chapter 176 of the Texas Local Government Code.

21. PATENTS: Seller agrees to **indemnify and hold harmless** the Buyer against all costs and expenses, including but not limited to attorneys fees, and undertakes and **agrees to defend** at seller's own expense, all suits, actions or proceedings in which Buyer or the users of Buyer's products are claimed to have conducted in, or are made defendants of, actual or alleged infringement of any U.S. or foreign patent or other intellectual property right resulting from the use or sale of the items purchased hereunder and further agrees to pay and discharge any and all judgments or decrees which may be rendered in any such suit, action or proceeding.

22. APPLICABLE LAW: This agreement shall be governed by the laws of the State of Texas, including but not limited to the Uniform Commercial Code as adopted by the State of Texas, as effective and in force on the date of this agreement, without regard to its conflict of laws rules or the conflict of law rules of any other jurisdiction.

23. VENUE: This agreement is performable in Dallas County, Texas, and venue for any suit, action, or legal proceeding under or in connection with this agreement shall lie exclusively in Dallas County, Texas. Proposer submits to the exclusive jurisdiction of the courts in Dallas County, Texas for purposes of any such suit, action, or proceeding hereunder, and waives any claim that any such suit, action, or legal proceeding has been brought in an inconvenient forum or that the venue of that proceeding is improper.

24. TERMINATION FOR CAUSE OR CONVENIENCE: The Town at any time after issuance of this agreement, by 30 days written notice to the Supplier, has the absolute write to terminate this agreement for cause or for convenience (that is, for any reason or no reason whatsoever). "Cause" shall be the Supplier's refusal or failure to satisfactorily perform or complete the work within the time specified, or failure to meet the specifications, quantities, quality and/or other requirements specified in the Contract/Purchase Order. In such case the Supplier shall be liable for any damages suffered by the Town. If the agreement is terminated for convenience, the Supplier has no further obligation under the agreement. Payment shall be made to cover the cost of material and work in process or "consigned" to the Town as of the effective date of the termination.

25. FORCE MAJEURE: To the extent either the Town or Proposer shall be wholly or partially prevented from the performance of this agreement or of any obligation or duty under this agreement placed on such party, by reason of or through work strikes, stoppage of labor, riot, fire, flood, acts of war, insurrection, court judgment, act of God, or other specific cause reasonably beyond the party's control and not attributable to its malfeasance, neglect or nonfeasance, then in such event, such party shall give notice of the same to the other party (specifying the reason for the prevention) and the time for performance of such obligation or duty shall be suspended until such disability to perform is removed.

26. BAFO: During evaluation process Town reserves the right to request a best and final offer upon completion of negotiations.

27. PROTECTION OF TRADE SECRETS OR PROPRIETARY INFORMATION: Proposals will be received and publicly acknowledged at the location, date, and time stated. Sellers, their representatives and interested persons may be present. The

proposals shall be received and acknowledged only so as to avoid disclosure of the contents to competing sellers and kept secret during negotiation. However, all proposals shall be open for public inspection after the contract is awarded. Trade secrets and confidential information contained in the proposal and identified by Seller in writing as such will be treated as confidential by the Town the extent allowable in the Texas Public Information Act and other law.

28. SILENCE OF SPECIFICATIONS: The apparent silence of these specifications as to any detail or to the apparent omission from it of a detailed description concerning any point, shall be regarded as meaning that only the best commercial practices are to prevail. All interpretations of these specifications shall be made on the basis of this statement.

29. PROPOSAL RESPONSE CONTRACTUAL OBLIGATION: This proposal, submitted documents, and any negotiations, when properly accepted by the Town, shall constitute a contract equally binding between the successful Proposer and the Town. No different or additional terms will become part of this contract except as properly executed in an addendum or change order.

30. NO BOYCOTTING ISRAEL. The entity contract with the Town of Addison does not boycott Israel and will not boycott Israel during the term of the contract. Reference HB 89 as it relates to Chapter 2270 of the Texas Government Code. Boycott Israel means refusing to deal with, terminating business activities with, or otherwise taking any action that is intended to penalize, inflict economic harm on, or limit commercial relations specifically with Israel or with a person or entity doing business in Israel or in an Israeli-controlled territory, but does not include an action made for ordinary business purposes.

Information and Instruction Form

RESPONSES THAT DO NOT CONTAIN THIS COMPLETED FORM MAY NOT BE COMPLIANT

Section I Company Profile

Name of Business: bkm Total Office Of Texas

Business Address: 9755 Clifford Drive, Ste 100 Dallas, Texas 75220

Contact Name: Carol Roehrig

Phone#: 214-902-7200

Fax#: 214-902-7201

Email: croehrig@bkmtexas.com

Name(s) Title of Authorized Company Officers: Steve Burak, CFO and Carol Roehrig, President

Federal ID #: W-9 Form: A W-9 form will be required from the successful bidder.

DUN #: 19-692-5952

Remit Address: If different than your physical address:

Section II Instructions to Bidders

Electronic Bids: The Town of Addison uses BidSync to distribute and receive bids and proposals. There will be **NO COST** to the Contractor/Supplier for Standard bids or proposals. For **Cooperative Bids and Reverse Auctions ONLY**, the successful contractor/supplier agrees to pay BidSync a transaction fee of one percent (1%) of the total amount of all contracts for goods and/or services. **Cooperative Bids and Reverse Auctions will be clearly marked on the bid documents**. To assure that all contractors/suppliers are treated fairly, the fee will be payable whether the bid/proposal is submitted electronically, or by paper means. Refer to www.bidsync.com for further information.

Contractor/Supplier Responsibility: It is the contractor/suppliers responsibility to check for any addenda or questions and answers that might have been issued before bid closing date and time. Contractors/Suppliers will be

notified of any addenda and Q&A if they are on the invited list, they view the bid, or add themselves to the watch list.

Acknowledgement of Addenda: #1 #2 #3 #4 #5

Delivery of Bids: For delivery of paper bids our physical address is:

Town of Addison

5350 Beltline Road

Dallas, TX 75254

Attn: Purchasing Department

Contractor/Supplier Employees: No Contractor/Supplier employee shall have a direct or indirect financial interest in any contract with the town, or be directly or indirectly financially interested in the sale of land, materials, supplies or services to the town.

Deliveries: All deliveries will be F.O.B. Town of Addison. All Transportation Charges paid by the contractor/supplier to Destination.

Payment Terms: A Prompt Payment Discount of % is offered for Payment Made Within Days of Acceptance of Goods or Services. If Prompt Payments are not offered or accepted, payments shall be made 30 days after receipt and acceptance of goods or services or after the date of receipt of the invoice whichever is later.

Delivery Dates: Delivery Dates are to be specified in Calendar Days from the Date of Order.

Bid Prices: Pre-Award bid prices shall remain Firm and Irrevocable for a Period of _____ Days.

Exceptions: Contractor/Supplier does not take Exception to Bid Specifications or Other Requirements of this Solicitation. If neither exceptions box is checked, default shall be "No Exceptions"

Contractor/Supplier take the following Exception(s) to the Bid Specifications or Other Requirements of this Solicitation (Explain in Detail). If box checked but no exceptions are listed, default shall be "No Exceptions"

Historically Underutilized Business (HUB): It is the policy of the Town of Addison to involve HUBs in the procurement of goods, equipment, services and construction projects. Prime Contractors/Suppliers are encouraged to provide HUBs the opportunity to compete for sub-contracting and other procurement opportunities. A listing of HUBs in this area may be accessed at the following State of Texas Website.
<http://www.window.state.tx.us/procurement/cmbl/cmblhub.html>.

HUB Owned Business Yes No Include a current copy of your HUB certification with your response or insert Certification number 1020549921200 and expire date August 26th, 2024.

Other Government Entities: Would bidder be willing to allow other local governmental entities to participate in this

contract, if awarded under the same Terms and Conditions? Yes No

Bid Bond: Is Bid Bond attached if applicable? Yes No

Termination: The town at any time after issuance of this agreement, by 30 days written notice, has the absolute right to terminate this agreement for cause or convenience. Cause shall be the contractor/supplier's refusal or failure to satisfactorily perform or complete the work within the time specified, or failure to meet the specifications, quantities, quality and/or other requirements specified in the contract/purchase order. In such case the supplier shall be liable for any damages suffered by the town. If the agreement is terminated for convenience, the supplier has no further obligation under the agreement. Payment shall be made to cover the cost of material and work in process or "consigned" to the town as of the effective date of the termination.

Bidder Compliance: Bidder agrees to comply with all conditions contained in this Information and Instruction Form and the additional terms and conditions and specifications included in this request. The undersigned hereby agrees to furnish and deliver the articles or services as specified at the prices and terms herein stated and in strict accordance with the specifications and conditions, all of which are made a part of your offer. Your offer is not subject to withdrawal after the award is made.

The Town of Addison reserves the right to reject all or part of the offer and to accept the offer considered most advantageous to the town by item or total bid.

The Town of Addison will award to the lowest responsible bidder or to the bidder who provides goods or services at the best value for the Town.

I hereby certify that all of the information provided in sections I and II are true and accurate to the best of my knowledge.

Signature: **Date:**

Title:

CFO

Signature certifies no changes have been made to the content of this solicitation as provided by the Town of Addison.

10/17/17

Question and Answers for Bid #20-231 - Addison Airport CBP Facility Furniture & Installation Services

Overall Bid Questions

There are no questions associated with this bid.