



TOWN OF ADDISON CHANGE ORDER FORM

---

**Change Order Number:** 2

**Project Name:** Addison Airport US Customs and Border Protection Facility

**Project Number(s):** 19-97

**Contractor Name:** JC Commercial, Inc.

**Date:** 05/20/2020

**A. INTENT OF CHANGE ORDER**

The purpose of this change order is to provide an amendment to the construction contract for JC Commercial to include the items mentioned below.

**B. DESCRIPTION OF CHANGE**

Items listed in section C will increase the contract amount to include unforeseen site conditions and requests from the US Customs and Border Protection Agency.

**C. REASON FOR CHANGE**

The following items will be included in the construction contract:

- Additional concrete pier depths were needed for the building foundation due to a variable depth rock layer that was deeper than anticipated. Additional pier depths ranged from 1.5 to 3.5 feet in depth and occurred outside the known rock layer depth provided in the geotechnical report. The pricing provided by JC Commercial is consistent with industry standards for cost per linear foot of pier depth for the additional work and material materials.
- Page (Architect) and AG&E (Structural Engineer) have both reviewed the proposal submittal by JC Commercial and agree the additional steel and erection cost associated with design revisions for building modifications is justified given this steel and detailing was added to the documents to accommodate layout revisions. Based on experience from the structural engineer, the cost submitted by JC Commercial appears to be approximately double what would be expected based on the erected steel tonnage involved in the change, but since the steel was already fabricated and on-site (which incurred trip charges and refabricating costs), the cost is reasonable. The steel modification required a high degree of detail and precision considering the modification was for the elevator enclosure and the contractor is required to complete the modifications based on the tight tolerances associated with the elevator installation.
- Accepted for additional site fill, excluding the building foundation footprint, due to the demolition operations performed under a separate contract removed existing soil and material that was not replaced back to the original survey grade. The site design earthwork quantity in the bid documents was calculated utilizing the average end area method based on the existing site survey before site demolition. JC Commercial performed a topographic survey of the site to verify the existing conditions before construction began and notified the project team the elevations of the site were lower

than the existing survey provided in the design documents. Also, additional fill was approved got placement along the western edge of the building foundation to protect the foundation edge until the airside improvements can be made under a separate construction contract executed by TxDOT Aviation.

- As requested by Customs and Border Protection, hold room toilets and lavatory were revised from separate toilets and lavatory to combination toilet/lavatory fixtures.

**D. EFFECT OF CHANGE ON CONTRACT PRICE**

This change order will have the following effect on the cost of this project:

Item Number/Description	Amount
Additional Foundation Pier Depths	\$11,466.65
Changes to Elevator Steel Structure	\$20,067.30
Additional Fill (Civil)	\$107,056.95
CBP Hold Room Combination Toilet/Lavatory Revision	\$3,290.20
<b>Subtotal</b>	<b>\$141,881.10</b>
Amount of this Change Order	\$141,881.10
Original Contract Amount	\$6,223,949.00
Overall Contract Amount (Including Previous Change Orders)	\$6,246,209.16
Revised Contract Amount	\$6,388,090.26
Total % Increase/Decrease (Including Previous Change Orders)	2.57%

**E. EFFECT OF CHANGE ON CONTRACT TIME**

The work required under this change will affect 25 days of the contract time.

Item Number/Description	Calendar Days
Additional Foundation Pier Depths	5
Changes to Elevator Steel Structure	10
Additional Fill (Civil)	10
<b>Subtotal</b>	<b>25</b>
Original Contract Start Date	September 30, 2019
Original Contract Time	450
Previously Approved Contract Time Extensions	0
Approved Contract Time Extensions this Change Order	25
New Contract Time	475
New Contract Completion Date	January 17, 2021

F. AGREEMENT

By the signatures below, duly authorized agent of the Town of Addison, and JC Commercial, Inc, do hereby agree to append this Change Order Number 2 to the original contract between themselves, dated September 18, 2019.

Lewisville TX 75057  
City State Zip

Phone: 972-436-4622

 5/27/20  
Contractor's Signature

  
Engineer's Signature  
Digitally Signed 05/29/2020

\_\_\_\_\_  
Project Manager

\_\_\_\_\_  
Department Director

\_\_\_\_\_  
Fin. & Strat. Services Representative

\_\_\_\_\_  
City Manager

Copies: Contractor (2)  
Department  
City Secretary

Council Agenda: Agenda Date \_\_\_\_\_  
(if applicable) Item Number \_\_\_\_\_  
Approved \_\_\_\_\_

## RFI Response

<b>RFI ID</b>	082		
<b>To</b>	Trevor Fitzgerald JC Commercial, Inc. 1801 Lakepointe Drive Suite 129 Lewisville TX 75057 United States (972) 436-4622	<b>From</b>	Will Butler Page Southerland Page, Inc. 1800 Main Street Suite 123 Dallas TX 75201 United States (469) 621 4837
<b>Project</b>	417151 - City of Addison Airport	<b>Project No.</b>	417151
<b>Date</b>	4/8/2020	<b>Transmittal ID</b>	00645
<b>Subject</b>	Proposal #11 - Additional Pier Depths		
<b>We are sending</b>	<input type="checkbox"/> Attached <input type="checkbox"/> Under Separate Cover	<b>Via</b>	Info Exchange

**Question:** Please see the attached proposal. I apologize that these proposals are out of order. The previous project engineer skipped over #11. Going forward this will not be an issue.

**Suggestion:**

**Answer:** **Response (Answered) from: Will Butler (Page Southerland Page, Inc.)**  
Remarks:

The proposal as submitted is reasonable and acceptable. We will work to include the proposal value indicated here in the next change order.

### Contents

Copies	Date	Number	Description
1	3/3/2020		RFI 82 - Proposal #11 - Additional Pier Depths (combined).pdf

**These are transmitted**  For review and comment  For your use  As requested

Please let me know if you need any additional information or clarification. Thank you.

**CC:** Darci Neuzil  
Jeff Mechlem  
Joe McAnally  
Joel Jenkinson  
Lisa Pyles  
Margarita de Monterrosa  
Michael Haskins  
Michelle LeBlanc  
Scott Arthur  
Will Butler



Request for Information 082

**Project Title:** Addison Airport Customs and Border Protection Facility  
**Submitted by Subcontractor:** JC Commercial

**Date Created:** 3/3/2020

Answer Company	Author Company	Authored By
Page Southerland Page, Inc. 1100 Louisiana, Suite One Houston, Texas 77002	JC Commercial 1801 Lakepointe Dr. Suite 129 Lewisville, TX 75057	Trevor Fitzgerald

**Subject:** Proposal #11 - Additional Pier Depths  
**Category:** Concrete

**Question:** **Date Required:** 3/10/2020

Please review the attached proposal for changes to the contract based on additional certified pier depths from the Fugro testing company.

**Answer:** **Date Answered:**



Pier Depths

Piers	G-2	F-7	E-7	A-7	A.5-7.2	A-6	A.5-6.2
Pier Size	36	36	36	24	24	24	24
Estimated Depth	14	14	14	11	11	11	11
Over Drilled Depth from Driller	0.9	0.3	0	0.5	0.5	0.7	1
Ground Surface Elevation	99.5	99.5	99.5	99.5	99.5	99.5	99.5
Top Of Shaft Elevation	97	97	97	97	97	97	97
Total Drilled Shaft Depth	14.6	14.4	13.1	14	13.6	14.3	14
Additional Depth of Pier	0.2	0.6	-0.4	3	2.6	3.1	2.5

Piers	H-7	H-6	F.8-6	F-6	E.7-5.1	D-5.2	C-5.2
Pier Size	24	24	24	24	24	24	24
Estimated Depth	11	11	11	11	11	11	11
Over Drilled Depth from Driller	0.8	0.6	2.7	2.7	0.6	0.7	0.6
Ground Surface Elevation	99.5	99.5	99.5	99.5	99.5	99.5	99.5
Top Of Shaft Elevation	97	97	97	97	97	97	97
Total Drilled Shaft Depth	15.6	15	13.7	13.8	11.6	14.6	14.1
Additional Depth of Pier	4.3	3.9	0.5	0.6	0.5	3.4	3

Piers	D-3	E-5	E.7-5.7	D.4-5.4	D-2	E.7-2	E-3
Pier Size	24	24	24	24	24	24	24
Estimated Depth	11	11	11	11	11	11	11
Over Drilled Depth from Driller	0.9	0.4	0.3	0.4	0.4	0.5	0.6
Ground Surface Elevation	99.5	99.5	99.5	99.5	99.5	99.5	99.5
Top Of Shaft Elevation	97	97	97	97	97	97	97
Total Drilled Shaft Depth	15.1	15	11.3	14.5	14.3	14.2	14.8
Additional Depth of Pier	3.7	4.1	0.5	3.6	3.4	3.2	3.7

Piers	C-4	E.6-6	F.8-6.5	F-6.5	D-6	D-7	G.5-D.5
Pier Size	24	24	24	24	24	36	18
Estimated Depth	11	11	11	11	11	14	11
Over Drilled Depth from Driller	2.4	0.5	0.9	0.7	0	0	0.2
Ground Surface Elevation	99.5	99.5	99.5	99.5	99.5	99.5	99.5
Top Of Shaft Elevation	97	97	97	97	97	97	97
Total Drilled Shaft Depth	13.5	14.3	16.2	14.2	14	15.2	11.5
Additional Depth of Pier	0.6	3.3	4.8	3	3.5	1.7	0.8

Piers	D.8-0.5	C.8-D.5	H-1	G.5-0.5	G-0.8	G.2-2.5	A-5
Pier Size	18	18	24	24	24	24	24
Estimated Depth	11	11	11	11	11	11	11
Over Drilled Depth from Driller	0	0.1	0.1	0	0	0	0.1
Ground Surface Elevation	99.5	99.5	99.5	99.5	99.5	99.5	99.5
Top Of Shaft Elevation	97	97	97	97	97	97	97
Total Drilled Shaft Depth	12.6	14.1	11.6	11.6	11.6	11.5	14
Additional Depth of Pier	2.1	3.5	1	1.1	1.1	1	3.4

Piers	B-2.3	A.9-4.4	A-1	C-1	C-2	E-1	B-3
Pier Size	24	24	36	36	36	36	36
Estimated Depth	11	11	14	14	14	14	14
Over Drilled Depth from Driller	0.1	0.1	0	0	0.1	0.3	0.1
Ground Surface Elevation	99.5	99.5	99.5	99.5	99.5	99.5	99.5
Top Of Shaft Elevation	97	97	97	97	97	97	97
Total Drilled Shaft Depth	13.6	13.5	16.8	16	16.1	14.9	15.1
Additional Depth of Pier	3	2.9	3.3	2.5	2.5	1.1	1.5

Piers	B-4	B-5.2	F-1	G-3	G-5	G-2	F-7
Pier Size	36	36	36	36	36	36	36
Estimated Depth	14	14	14	14	14	14	14
Over Drilled Depth from Driller	0	0	0.2	0	0.3	0.9	0.3
Ground Surface Elevation	99.5	99.5	99.5	99.5	99.5	99.5	99.5
Top Of Shaft Elevation	97	97	97	97	97	97	97
Total Drilled Shaft Depth	15	15	14.2	13.7	13.8	14.6	14.1
Additional Depth of Pier	1.5	1.5	0.5	0.2	0	0.2	0.3

Piers	E-7	A-7	A.5-7.2	A-6	A.5-6.2		
Pier Size	36	24	24	24	24		
Estimated Depth	14	11	11	11	11		
Over Drilled Depth from Driller	0	0.5	0.5	0.7	1		
Ground Surface Elevation	99.5	99.5	99.5	99.5	99.5		
Top Of Shaft Elevation	97	97	97	97	97		
Total Drilled Shaft Depth	13.1	14	13.6	14.3	14		
Additional Depth of Pier	-0.4	3	2.6	3.1	2.5		

Total Additional LF	
112.70'	\$ 81.02

Grand Total: \$9130.95





Fugro USA Land, Inc.  
2880 Virgo Lane  
Dallas, Texas 75229  
Phone (972) 484-8301, Fax (972) 620-7328

## DAILY FIELD SUMMARY REPORT

**Project:** Addison Airport CBPF  
**Client:** Town of Addison  
16801 Westgrove Dr.  
Addison, TX 75001

**Service Date:** 11/13/2019  
**Report Date:** 11/14/2019  
**Project No.:** 04.40192101  
**Lab / Report No.:** 21141-1 / 0023

---

Page 1 of 4

### Summary of Field Activities and Observations

On this date the representative of Fugro USA Land, Inc. noted below was present at the project site to perform services as scheduled.

Pier foundation installation observation services were performed. A total of 18 piers were installed. See the attached "Drilled Pier Observation Report" for additional details.

**Fugro Representative:** James Pacheco: Left for Job: 6:30 am : Arrive: 7:00 am Depart:  
5:00 pm  
Travel: 1.0 Total Billable Hours: R/T: 11.0

**Fugro USA Land, Inc.**  
TBPE Firm Registration No. F-299

---

Muhammad Khan  
Project Manager

THE ABOVE TEST RESULTS APPLY ONLY TO THE ITEMS TESTED.  
THIS REPORT SHALL NOT BE REPRODUCED EXCEPT IN FULL WITHOUT THE APPROVAL OF FUGRO USA LAND, INC.



Fugro Dallas  
 2880 Virgo Lane  
 Dallas, TX 75229  
 Phone: (972) 484-8301  
 Work Order#21141 Rpt#0023

**DRILLED PIER OBSERVATION REPORT**

Client: Town of Addison  
 Project: Addison Airport  
 Date: 11/13/19

Project No: 04.40192101  
 Drilling Firm: Maxon Drilling  
 Page 1 of 3

Pier Identification: <b>Building Pad</b>		G-2	F-7	E-7	A-7	A.5-7.2	A-6	A.5-6.2
Pier Diameter, in.	Required	36	36	36	24	24	24	24
	Actual	36	36	36	24	24	24	24
Time Drilling Started		8:00	8:25	8:58	9:20	9:37	9:49	10:03
Top of Ground Elevation, ft. <sup>(1)</sup>		99.8	99.8	99.8	99.8	99.8	99.8	99.8
Top of Pier Elevation, ft		97.0	97.0	97.0	97.0	97.0	97.0	97.0
Required Depth, ft.		8.70	8.80	8.10	10.50	10.10	10.60	10.00
Total Depth, ft.		14.60	14.10	13.10	14.00	13.60	14.30	14.00
Peneration ft.	Required	5.00	5.00	5.00	5.00	5.00	5.00	5.00
	Actual	5.90	5.30	5.00	3.50	3.50	3.70	4.00
Casing	Dia., in.	N/A	N/A	N/A	N/A	N/A	N/A	N/A
	Length, ft	N/A	N/A	N/A	N/A	N/A	N/A	N/A
Plumb within Tolerance (Yes/No):		YES	YES	YES	YES	YES	YES	YES
Vertical Reinforcing	Bar Size	#8	#8	#8	#6	#6	#6	#6
	Quantity	12	12	12	6	6	6	6
	Length, ft	11.70	11.20	10.20	11.10	10.70	11.40	11.10
Horizontal Reinforcing	Bar Size	#3	#3	#3	#3	#3	#3	#3
	Spacing, in	12	12	12	12	12	12	12
Time Concrete Placed		11:40	11:40	11:42	11:43	11:46	11:48	13:20
Condition of Bottom before Concrete Placement (Wet / Dry)		DRY	DRY	DRY	DRY	DRY	DRY	DRY
Time Drilling Completed		8:24	8:57	9:19	9:36	9:48	10:02	10:17

Remarks:

Tech: James Pacheco

FUGRO USA Land, INC.  
 TBPE Firm Registration No. F-299

Muhammad Khan, P.E.  
 Project Manager

The results shown on this report are for the exclusive use of the client for whom they were obtained and apply only to the samples tested and/or observed. They are not intended to be indicative of the qualities of apparently identical products. The use of our name must receive prior written approval. Reports must be reproduced in their entirety.



Fugro Dallas  
 2880 Virgo Lane  
 Dallas, TX 75229  
 Phone: (972) 484-8301

Work Order#21141 Rpt#0023

**DRILLED PIER OBSERVATION REPORT**

Client: Town of Addison  
 Project: Addison Airport  
 Date: 11/13/19

Project No: 04.40192101  
 Drilling Firm: Maxon Drilling  
 Page 2 of 3

Pier Identification: <b>Building Pad</b>		H-7	H-6	** F.8-6	** F-6	E.7-5.1	D-5.2	C-5.2
Pier Diameter, in.	Required	24	24	24	24	24	24	24
	Actual	24	24	24	24	24	24	24
Time Drilling Started		10:18	10:38	10:53	11:05	11:22	11:37	11:50
Top of Ground Elevation, ft. <sup>(1)</sup>		99.8	99.8	99.8	99.8	99.8	99.8	99.8
Top of Pier Elevation, ft		97.0	97.0	93.6	93.6	97.0	97.0	97.0
Required Depth, ft.		11.80	11.40	8.00	8.10	8.00	10.90	10.50
Total Depth, ft.		15.60	15.00	13.70	13.80	11.60	14.60	14.10
Penetration ft.	Required	3.00	3.00	3.00	3.00	3.00	3.00	3.00
	Actual	3.80	3.60	5.70	5.70	3.60	3.70	3.60
Casing	Dia., in.	N/A	N/A	N/A	N/A	N/A	N/A	N/A
	Length, ft	N/A	N/A	N/A	N/A	N/A	N/A	N/A
Plumb within Tolerance (Yes/No):		YES	YES	YES	YES	YES	YES	YES
Vertical Reinforcing	Bar Size	#6	#6	#6	#6	#6	#6	#6
	Quantity	6	6	6	6	6	6	6
	Length, ft	12.70	12.10	7.40	7.50	8.70	11.70	11.20
Horizontal Reinforcing	Bar Size	#3	#3	#3	#3	#3	#3	#3
	Spacing, in	12	12	12	12	12	12	12
Time Concrete Placed		13:30	13:35	13:38	13:43	13:50	15:10	15:05
Condition of Bottom before Concrete Placement (Wet / Dry)		DRY	DRY	DRY	DRY	DRY	DRY	DRY
Time Drilling Completed		10:37	10:52	11:04	11:21	11:36	11:49	12:03

Remarks: Piers F.8-6 & F-6 are for Elevator Shaft. Due to elevation of top of pier , had to drill deeper to achieve min per length.

Tech: James Pacheco

FUGRO USA Land, INC.  
 TBPE Firm Registration No. F-299

Muhammad Khan, P.E.  
 Project Manager

The results shown on this report are for the exclusive use of the client for whom they were obtained and apply only to the samples tested and/or observed. They are not intended to be indicative of the qualities of apparently identical products. The use of our name must receive prior written approval. Reports must be reproduced in their entirety.



Fugro Dallas

2880 Virgo Lane

Dallas, TX 75229

Phone: (972) 484-8301

Work Order#21141 Rpt#0023

**DRILLED PIER OBSERVATION REPORT**

Client: Town of Addison  
 Project: Addison Airport  
 Date: 11/13/19

Project No: 04.40192101  
 Drilling Firm: Maxon Drilling  
 Page 3 of 3

Pier Identification: <b>Building Pad</b>		D-3	E-5	E 7-5.7	D.4-5.4			
Pier Diameter, in.	Required	24	24	18	18			
	Actual	24	24	18	18			
Time Drilling Started		12:45	13:00	13:10	13:50			
Top of Ground Elevation, ft. <sup>(1)</sup>		99.8	99.8	99.8	99.8			
Top of Pier Elevation, ft		97.0	97.0	97.0	97.0			
Required Depth, ft.		11.20	11.60	8.00	11.10			
Total Depth, ft.		15.10	15.00	11.30	14.50			
Peneration ft.	Required	3.00	3.00	3.00	3.00			
	Actual	3.90	3.40	3.30	3.40			
Casing	Dia., in.	N/A	N/A	N/A	N/A			
	Length, ft	N/A	N/A	N/A	N/A			
Plumb within Tolerance (Yes/No):		YES	YES	YES	YES			
Vertical Reinforcing	Bar Size	#6	#6	#6	#6			
	Quantity	12	12	12	12			
	Length, ft	12.20	12.10	8.40	11.60			
Horizontal Reinforcing	Bar Size	#3	#3	#3	#3			
	Spacing, in	12	12	12	12			
Time Concrete Placed		12:59	13:05	13:22	14:05			
Condition of Bottom before Concrete Placement (Wet / Dry)		DRY	DRY	DRY	DRY			
Time Drilling Completed		15:15	15:25	15:30	15:40			

Remarks:

Tech: James Pacheco

FUGRO USA Land, INC.  
 TBPE Firm Registration No. F-299

Muhammad Khan, P.E.  
 Project Manager

The results shown on this report are for the exclusive use of the client for whom they were obtained and apply only to the samples tested and/or observed. They are not intended to be indicative of the qualities of apparently identical products. The use of our name must receive prior written approval. Reports must be reproduced in their entirety.



Fugro USA Land, Inc.  
2880 Virgo Lane  
Dallas, Texas 75229  
Phone (972) 484-8301, Fax (972) 620-7328

## DAILY FIELD SUMMARY REPORT

**Project:** Addison Airport CBPF  
**Client:** Town of Addison  
16801 Westgrove Dr.  
Addison, TX 75001

**Service Date:** 11/14/2019  
**Report Date:** 11/25/2019  
**Project No.:** 04.40192101  
**Lab / Report No.:** 21142-1 / 0027

---

Page 1 of 3

### Summary of Field Activities and Observations

On this date the representative of Fugro USA Land, Inc. noted below was present at the project site to perform services as scheduled.

Pier foundation installation observation services were performed. A total of 9 piers were installed. See the attached "Drilled Pier Observation Report" for additional details.

**Fugro Representative:** James Pacheco: Left for Job: 6:30 am : Arrive: 7:00 am Depart:  
4:00 pm  
Travel: 1.0 Total Billable Hours: R/T: 10.0

**Fugro USA Land, Inc.**  
TBPE Firm Registration No. F-299

*Ahan*

---

Muhammad Khan  
Project Manager

THE ABOVE TEST RESULTS APPLY ONLY TO THE ITEMS TESTED.  
THIS REPORT SHALL NOT BE REPRODUCED EXCEPT IN FULL WITHOUT THE APPROVAL OF FUGRO USA LAND, INC.



Fugro Dallas  
2880 Virgo Lane  
Dallas, TX 75229  
Phone: (972) 484-8301

Work Order#21142 Rpt#0027

DRILLED PIER OBSERVATION REPORT

Client: Town of Addison  
Project: Addison Airport  
Date: 11/14/19

Project No: 04.40192101  
Drilling Firm: Maxon Drilling  
Page 1 of 2

Pier Identification: <b>Building Pad</b>		D-2	E.7-2	E-3	C-4	E.6-6	*F.8-6.5	*F-6.5
Pier Diameter, in.	Required	24	24	24	24	24	24	24
	Actual	24	24	24	24	24	24	24
Time Drilling Started		8:00	8:26	8:43	9:10	9:27	9:49	10:19
Top of Ground Elevation, ft. <sup>(1)</sup>		99.8	99.8	99.8	99.8	99.8	99.8	99.80
Top of Pier Elevation, ft		97.0	97.0	97.0	97.0	97.0	91.6	93.60
Required Depth, ft.		10.90	10.70	11.20	10.00	8.20	8.40	8.40
Total Depth, ft.		14.30	14.20	14.80	13.50	14.30	16.20	14.20
Peneration ft.	Required	3.00	3.00	3.00	3.00	3.00	3.00	3.00
	Actual	3.40	3.50	3.60	3.50	6.10	7.80	5.80
Casing	Dia., in.	N/A	N/A	N/A	N/A	N/A	N/A	N/A
	Length, ft	N/A	N/A	N/A	N/A	N/A	N/A	N/A
Plumb within Tolerance (Yes/No):		YES	YES	YES	YES	YES	YES	YES
Vertical Reinforcing	Bar Size	#6	#6	#6	#6	#6	#6	#6
	Quantity	6	6	6	6	6	6	6
	Length, ft	11.40	11.30	11.90	10.60	11.40	7.90	7.90
Horizontal Reinforcing	Bar Size	#3	#3	#3	#3	#3	#3	#3
	Spacing, in	12	12	12	12	12	12	12
Time Concrete Placed		8:25	8:42	9:09	9:26	9:48	10:18	10:37
Condition of Bottom before Concrete Placement (Wet / Dry)		DRY	DRY	DRY	DRY	DRY	DRY	DRY
Time Drilling Completed		15:10	15:15	15:22	15:31	13:41	13:32	13:28

Remarks: \*Piers F.8-6.5 & F-6.5, Due to top of pier elevation, we had to drill deeper to achieve min pier length.

Tech: James Pacheco

FUGRO USA Land, INC.  
TBPE Firm Registration No. F-299

Muhammad Khan, P.E.  
Project Manager

The results shown on this report are for the exclusive use of the client for whom they were obtained and apply only to the samples tested and/or observed. They are not intended to be indicative of the qualities of apparently identical products. The use of our name must receive prior written approval. Reports must be reproduced in their entirety.



Fugro Dallas  
 2880 Virgo Lane  
 Dallas, TX 75229  
 Phone: (972) 484-8301  
 Work Order#21142 Rpt#0027

**DRILLED PIER OBSERVATION REPORT**

Client: Town of Addison  
 Project: Addison Airport  
 Date: 11/14/19

Project No: 04.40192101  
 Drilling Firm: Maxon Drilling  
 Page 2 of 2

Pier Identification: <b>Building Pad</b>		D-6	D-7				
Pier Diameter, in.	Required	24	24				
	Actual	24	24				
Time Drilling Started		10:30	10:55				
Top of Ground Elevation, ft. <sup>(1)</sup>		99.8	99.8				
Top of Pier Elevation, ft		97.0	97.0				
Required Depth, ft.		11.00	10.20				
Total Depth, ft.		14.00	15.20				
Penetration ft.	Required	3.00	5.00				
	Actual	3.00	5.00				
Casing	Dia., in.	N/A	N/A				
	Length, ft	N/A	N/A				
Plumb within Tolerance (Yes/No):		YES	YES				
Vertical Reinforcing	Bar Size	#6	#8				
	Quantity	6	12				
	Length, ft	11.10	12.30				
Horizontal Reinforcing	Bar Size	#3	#3				
	Spacing, in	12	12				
Time Concrete Placed		10:50	11:15				
Condition of Bottom before Concrete Placement (Wet / Dry)		DRY	DRY				
Time Drilling Completed		13:20	13:15				

Remarks:

Tech: James Pacheco

FUGRO USA Land, INC.  
 TBPE Firm Registration No. F-299

Muhammad Khan, P.E.  
 Project Manager

The results shown on this report are for the exclusive use of the client for whom they were obtained and apply only to the samples tested and/or observed. They are not intended to be indicative of the qualities of apparently identical products. The use of our name must receive prior written approval. Reports must be reproduced in their entirety.



**Fugro USA Land, Inc.**

2880 Virgo Lane

Dallas, Texas 75229

Phone (972) 484-8301, Fax (972) 620-7328

## DAILY FIELD SUMMARY REPORT

**Project:** Addison Airport CBPF  
**Client:** Town of Addison  
16801 Westgrove Dr.  
Addison, TX 75001

**Service Date:** 11/06/2019  
**Report Date:** 11/13/2019  
**Project No.:** 04.40192101  
**Lab / Report No.:** 21055-1 / 0020

---

Page 1 of 4

### Summary of Field Activities and Observations

On this date the representative of Fugro USA Land, Inc. noted below was present at the project site to perform services as scheduled.

Pier foundation installation observation services were performed. A total of 20 piers were installed. See the attached "Drilled Pier Observation Report" for additional details.

**Fugro Representative:** James Pacheco: Left for Job: 6:30 am : Arrive: 7:00 am Depart:  
5:00 pm  
Travel: 1.0 Total Billable Hours: R/T: 11.0

**Fugro USA Land, Inc.**  
TBPE Firm Registration No. F-299

*Ahan*

Muhammad Khan  
Project Manager

THE ABOVE TEST RESULTS APPLY ONLY TO THE ITEMS TESTED  
THIS REPORT SHALL NOT BE REPRODUCED EXCEPT IN FULL WITHOUT THE APPROVAL OF FUGRO USA LAND, INC.





Fugro Dallas  
 2880 Virgo Lane  
 Dallas, TX 75229  
 Phone: (972) 484-8301

Work Order#21055 Rpt#0020

**DRILLED PIER OBSERVATION REPORT**

Client: Town of Addison  
 Project: Addison Airport  
 Date: 11/06/19

Project No: 04.40192101  
 Drilling Firm: Maxon Drilling  
 Page 1 of 3

Pier Identification: <b>Building Pad</b>		G.5-D.5	D.8-O.5	C.8-D.5	H-1	G.5-O.5	G-O.8	G.2-2.5
Pier Diameter, in.	Required	18	18	18	24	24	24	24
	Actual	18	18	18	30	30	24	24
Time Drilling Started		8:00	8:30	8:51	9:08	9:23	9:37	9:56
Top of Ground Elevation, ft. <sup>(1)</sup>		99.8	99.8	99.8	99.8	99.8	99.8	99.8
Top of Pier Elevation, ft		97.0	97.0	97.0	97.0	97.0	97.0	97.0
Required Depth, ft.		8.30	9.60	11.00	8.50	8.60	8.60	8.50
Total Depth, ft.		11.50	12.60	14.10	11.60	11.60	11.60	11.50
Penetration ft.	Required	3.00	3.00	3.00	3.00	3.00	3.00	3.00
	Actual	3.20	3.00	3.10	3.10	3.00	3.00	3.00
Casing	Dia., in.	N/A	N/A	N/A	N/A	N/A	N/A	N/A
	Length, ft	N/A	N/A	N/A	N/A	N/A	N/A	N/A
Plumb within Tolerance (Yes/No):		YES	YES	YES	YES	YES	YES	YES
Vertical Reinforcing	Bar Size	#6	#6	#6	#6	#6	#6	#6
	Quantity	5	5	5	6	6	6	6
	Length, ft	8.60	9.70	11.20	8.70	8.70	8.70	8.60
Horizontal Reinforcing	Bar Size	#3	#3	#3	#3	#3	#3	#3
	Spacing, in	12	12	12	12	12	12	12
Time Drilling Completed		8:29	8:50	9:07	9:22	9:36	9:55	10:13
Condition of Bottom before Concrete Placement (Wet / Dry)		DRY	DRY	DRY	DRY	DRY	DRY	DRY
Time Concrete Placed		12:30	12:34	12:45	12:56	13:01	13:08	13:15

Remarks:

Tech: James Pacheco

FUGRO USA Land, INC.  
 TBPE Firm Registration No. F-299

Muhammad Khan, P.E.  
 Project Manager

The results shown on this report are for the exclusive use of the client for whom they were obtained and apply only to the samples tested and/or observed. They are not intended to be indicative of the qualities of apparently identical products. The use of our name must receive prior written approval. Reports must be reproduced in their entirety.



Fugro Dallas  
 2880 Virgo Lane  
 Dallas, TX 75229  
 Phone: (972) 484-8301

Work Order#21055 Rpt#0020

**DRILLED PIER OBSERVATION REPORT**

Client: Town of Addison  
 Project: Addison Airport  
 Date: 11/06/19

Project No: 04.40192101  
 Drilling Firm: Maxon Drilling  
 Page 2 of 3

Pier Identification: <b>Building Pad</b>		A-2	B-2.3	A.9-4.4	A-1	C-1	C-2	E-1
Pier Diameter, in.	Required	24	24	24	36	36	36	36
	Actual	24	24	24	36	36	36	36
Time Drilling Started		10:14	10:30	10:50	11:09	11:34	12:03	12:39
Top of Ground Elevation, ft. <sup>(1)</sup>		99.8	99.8	99.8	99.8	99.8	99.8	99.8
Top of Pier Elevation, ft		97.0	97.0	97.0	97.0	97.0	97.0	97.0
Required Depth, ft.		11.00	10.50	10.40	11.80	11.00	11.00	9.60
Total Depth, ft.		14.00	13.60	13.50	16.80	16.00	16.10	14.90
Peneration ft.	Required	3.00	3.00	3.00	5.00	5.00	5.00	5.00
	Actual	3.00	3.10	3.10	5.00	5.00	5.10	5.30
Casing	Dia., in.	N/A	N/A	N/A	N/A	N/A	N/A	N/A
	Length, ft	N/A	N/A	N/A	N/A	N/A	N/A	N/A
Plumb within Tolerance (Yes/No):		YES	YES	YES	YES	YES	YES	YES
Vertical Reinforcing	Bar Size	#6	#6	#6	#8	#8	#8	#8
	Quantity	6	6	6	12	12	12	12
	Length, ft	11.10	10.70	10.60	13.90	13.10	13.20	12.00
Horizontal Reinforcing	Bar Size	#3	#3	#3	#3	#3	#3	#3
	Spacing, in	12	12	12	12	12	12	12
Time Drilling Completed		10:29	10:49	11:03	11:33	12:02	12:38	13:05
Condition of Bottom before Concrete Placement (Wet / Dry)		DRY	DRY	DRY	DRY	DRY	DRY	DRY
Time Concrete Placed		13:21	13:28	13:36	15:50	15:56	16:05	16:13

Remarks:

Tech: James Pacheco

FUGRO USA Land, INC.  
 TBPE Firm Registration No. F-299

Muhammad Khan, P.E.  
 Project Manager

The results shown on this report are for the exclusive use of the client for whom they were obtained and apply only to the samples tested and/or observed. They are not intended to be indicative of the qualities of apparently identical products. The use of our name must receive prior written approval. Reports must be reproduced in their entirety.



Fugro Dallas  
2880 Virgo Lane  
Dallas, TX 75229

Phone: (972) 484-8301

Work Order#21055 Rpt#0020

**DRILLED PIER OBSERVATION REPORT**

Client: Town of Addison  
Project: Addison Airport  
Date: 11/06/19

Project No: 04.40192101  
Drilling Firm: Maxon Drilling  
Page 3 of 3

Pier Identification: <b>Building Pad</b>		B-3	B-4	B-5.2	F-1	G-3	G-5	
Pier Diameter, in.	Required	36	36	36	36	36	36	
	Actual	36	36	36	36	36	36	
Time Drilling Started		13:06	13:32	13:56	14:23	14:52	15:23	
Top of Ground Elevation, ft. <sup>(1)</sup>		99.8	99.8	99.8	99.8	99.8	99.8	
Top of Pier Elevation, ft		97.0	97.0	97.0	97.0	97.0	97.0	
Required Depth, ft.		10.00	10.00	10.00	9.00	8.70	8.50	
Total Depth, ft.		15.10	15.00	15.00	14.20	13.70	13.80	
Penetration ft.	Required	5.00	5.00	5.00	5.00	5.00	5.00	
	Actual	5.10	5.00	5.00	5.20	5.00	5.30	
Casing	Dia., in.	N/A	N/A	N/A	N/A	N/A	N/A	
	Length, ft	N/A	N/A	N/A	N/A	N/A	N/A	
Plumb within Tolerance (Yes/No):		YES	YES	YES	YES	YES	YES	
Vertical Reinforcing	Bar Size	#8	#8	#8	#8	#8	#8	
	Quantity	12	12	12	12	12	12	
	Length, ft	12.20	14.10	12.10	11.30	10.80	10.90	
Horizontal Reinforcing	Bar Size	#3	#3	#3	#3	#3	#3	
	Spacing,	12	12	12	12	12	12	
Time Drilling Completed		13:31	13:55	14:24	14:51	15:22	15:56	
Condition of Bottom before Concrete Placement (Wet / Dry)		DRY	DRY	DRY	DRY	DRY	DRY	
Time Concrete Placed		16:22	16:29	16:40	16:47	16:59	17:05	

Remarks:

Tech: James Pacheco

FUGRO USA Land, INC.  
TBPE Firm Registration No. F-299

Muhammad Khan, P.E.  
Project Manager

The results shown on this report are for the exclusive use of the client for whom they were obtained and apply only to the samples tested and/or observed. They are not intended to be indicative of the qualities of apparently identical products. The use of our name must receive prior written approval. Reports must be reproduced in their entirety.

## RFI Response

<b>RFI ID</b>	087		
<b>To</b>	Trevor Fitzgerald JC Commercial, Inc. 1801 Lakepointe Drive Suite 129 Lewisville TX 75057 United States (972) 436-4622	<b>From</b>	Page CA Department Page Southerland Page, Inc. 1100 Louisiana Suite One Houston TX 77002 United States (713) 871-8484
<b>Project</b>	417151 - City of Addison Airport	<b>Project No.</b>	417151
<b>Date</b>	4/24/2020	<b>Transmittal ID</b>	00676
<b>Subject</b>	Proposal #10 - Changes to the Elevator		
<b>We are sending</b>	<input type="checkbox"/> Attached <input type="checkbox"/> Under Separate Cover	<b>Via</b>	Info Exchange

**Question:** Per the response to RFI #70, we are resubmitting proposal #10 with the following information as justification for the pricing:

It is very difficult to erect straight enough and plum enough to work with the mechanics of the car. The modifications that came out affected a number of other pieces. Four of these were already on site and had to be picked up and brought back to the shop to be refitted and then delivered once again. In regards to the labor price, the subcontractor uses his shop foreman and best fitter welders to install these items not his regular iron working crew. These guys make considerably more than the normal journeyman iron worker.

**Suggestion:**

**Answer:** **Response (Answered) from: Will Butler (Page Southerland Page, Inc.)**  
Remarks:

Page and AG&E have both reviewed the proposal and agree that the added steel and erection cost request is justified given when this steel and detailing was added to the documents. We do believe that the GC is owed some costs for this work and materials. Based on AG&E past experience, the cost submitted appears to be approximately double what would be expected based on the erected steel tonnage involved in the change. Upon further review and discussions with the GC and subcontractor, they have refused to reduce these costs and again referenced the fact that modifications had to be made to steel that was already fabricated and on-site (which incurred trip charges and re-fabricating costs). They also pointed out that a high degree of detail and precision is required when doing this type of elevator work due to tight elevator tolerances and because of this they have high costs for the

labor to complete this work.

We will include the submitted cost proposal value with the next change order (CO #2) along with our response above for Owner review and comment.

## Contents

Copies	Date	Number	Description
1	3/19/2020		RFI 87 - Proposal #10 - Changes to the Elevator.pdf

**These are transmitted**

For review and comment

For your use

As requested

Please let me know if you need any additional information or clarification. Thank you.

**CC:**

Darci Neuzil  
Jeff Mechlem  
Joe McAnally  
Joel Jenkinson  
Lisa Pyles  
Margarita de Monterrosa  
Michelle LeBlanc  
Scott Arthur  
Will Butler



Request for Information 87

Project Title: Addison Airport Customs and Border Protection Facility Submitted by Subcontractor:

Date Created: 3/19/2020

Table with 3 columns: Answer Company, Author Company, Authored By. Includes details for Page Southerland Page, Inc. and JC Commercial.

Subject: Proposal #10 - Changes to Elevator Category: Structural

Question: Date Required: 3/26/2020

Per the response to RFI #70, we are resubmitting proposal #10 with the following information as justification for the pricing: It is very difficult to erect straight enough and plum enough to work with the mechanics of the car. The modifications that came out affected a number of other pieces. Four of these were already on site and had to be picked up and brought back to the shop to be refitted and then delivered once again. In regards to the labor price, the subcontractor uses his shop foreman and best fitter welders to install these items not his regular iron working crew. These guys make considerably more than the normal journeyman iron worker.

Answer: Date Answered:



## Proposal #10

Project: Addison Airport Customs and Border Protection Facility  
 Date: 1/31/2020  
 Attn: Jeff Meclem, Mitchell McAnally  
Will Butler, Vlad Stevanovic

Customer: Town of Addison  
5350 Beltline Road  
Dallas, Texas 75254  
 Architect: Page Southerland Page  
1100 Louisiana Street, Suite One  
Houston, Texas 77002

This Proposal contains an itemized quotation for changes in the Contract Sum and/or Contract Time in response to proposed modifications to the Contract Documents based on \_\_\_\_\_

Item	Description	Total
1	Changes to Elevator SK1 and SK2	\$ 15,979.70
Sub-total		\$ 15,979.70
General Conditions		\$ 798.99
Sub-total		\$ 16,778.69
Insurance		\$ 335.57
Bond		\$ 335.57
Sub-total		\$ 17,449.83
Mark up		\$ 2,617.47
<b>Total</b>		<b>\$ 20,067.30</b>

Does Proposed Change involve a change in Contract Sum?	<input type="checkbox"/> No	<input checked="" type="checkbox"/> Yes	[Increase / Decrease]	\$20,067.30
Does Proposed Change involve a change in Contract Time?	<input type="checkbox"/> No	<input checked="" type="checkbox"/> Yes	[Increase / Decrease]	Days 10

JC Commercial <b>CONTRACTOR</b> 1801 Lakepointe Drive, Suite #129 Lewisville, TX 75057	Architect
---	-----------

By: **Scott Arthur**  
 Signature: *Scott Arthur*  
 Date: 1/31/2020

By: \_\_\_\_\_  
 Signature: \_\_\_\_\_  
 Date: \_\_\_\_\_

**Change in Work - Cost Analysis Form**

Project Name: Assuan Airport  
 Contractor: Siccance  
 Description of Change: Changes of elevator SK-1 and SK-2

Project No.: 19-010  
 Change No.: 1

Means Code	Page No.	DESCRIPTION	Quantity	Unit	Cost per hundred weight	Cost per pound	Cost per sq. ft.	Total Hourly Rate	Labor Total	Material Total	Equipment or Other	Subcontract	
		<b>Lebor</b>											
		Shop Labor	54	Hrs				85.00	\$4,590.00				
		Field labor erection	90	HRS				39.50	\$3,555.00	-	-	-	
		Office hours	8	HRS				65.00	\$520.00	-	-	-	
		<b>Material</b>											
		tube steel, angles, embeds	1	loc.	\$ 4,272.00				-	\$4,272.00	-	-	
		<b>Equipment</b>											
		forklift	1	Day	\$ 125.00						\$125.00		
		scissor lift	1	Day	\$ 85.00						\$85.00		
		truck expense	1	day	\$ 250.00						\$250.00		
			0	Day	\$ 635.00						\$0.00		
			0	Day	\$ 180.00						\$0.00		
			0	Day	\$ 180.00						\$0.00		
		Delivery	1	Per	\$ 130.00						\$130.00		
		<b>Subcontractor (Detailer)</b>											
			0.68	EA	\$ 400.00							\$1,000.00	
			0	SF	\$ 1.25	Per. Month	2.00					\$0.00	
												\$0.00	
		<b>SUBTOTALS</b>								<b>\$8,665.00</b>	<b>\$4,272.00</b>	<b>\$590.00</b>	<b>\$1,000.00</b>

Lebor, Equipment, & Material Total	\$13,527.00
Subcontractor	\$1,000.00
Overhead and Profit	\$1,452.70
Taxes	\$0.00
<b>TOTAL FOR THIS CHANGE</b>	<b>\$15,979.70</b>

**Material** All material is furnished up  
 All material has a \$130.00 Delivery Fee in DFW

**Equipment** Equipment is rented by the day. Anything over 3 days goes to 1 week. Anything over 2 weeks goes to 4 weeks.  
 All equipment has a pick up and delivery charge of \$130.00. This includes small equipment.



## RFI Response

<b>RFI ID</b>	086		
<b>To</b>	Trevor Fitzgerald JC Commercial, Inc. 1801 Lakepointe Drive Suite 129 Lewisville TX 75057 United States (972) 436-4622	<b>From</b>	Page CA Department Page Southerland Page, Inc. 1100 Louisiana Suite One Houston TX 77002 United States (713) 871-8484
<b>Project</b>	417151 - City of Addison Airport	<b>Project No.</b>	417151
<b>Date</b>	4/6/2020	<b>Transmittal ID</b>	00643
<b>Subject</b>	Proposal #16 - Additional Fill (Civil)		
<b>We are sending</b>	<input type="checkbox"/> Attached <input type="checkbox"/> Under Separate Cover	<b>Via</b>	Info Exchange

**Question:** Please see the attached proposal.

**Suggestion:**

**Answer:** **Response (Answered) from: Vladimir Stevanovic (Garver)**  
**Remarks:**

### Contents

Copies	Date	Number	Description
1	3/19/2020		RFI #86 - Proposal #16 - Additional Fill (Civil).pdf

**These are transmitted**  For review and comment  For your use  As requested

Please let me know if you need any additional information or clarification. Thank you.

**CC:** Darci Neuzil  
Jeff Mechlem  
Joe McAnally  
Joel Jenkinson  
Lisa Pyles  
Margarita de **Monterrosa**  
Michael Haskins  
Michelle LeBlanc  
Scott Arthur  
Will Butler



**Proposal #16**

Project: <u>Addison Airport Customs and Border Protection Facility</u>  Date: <u>3/19/2020</u>  Attn: <u>Jeff Mechlem, Mitchell McAnally Will Butler, Vlad Stevanovic</u>	Customer: <u>Town of Addison 5350 Beltline Road Dallas, Texas 75254</u>  Architect: <u>Page Southerland Page 1100 Louisiana Street, Suite One Houston, Texas 77002</u>
---	--

This Proposal contains a quotation for changes in the Contract Sum and/or Contract Time in response to proposed modifications to the Contract Documents based on RFI 13 and field directive from Garver/Page.

Item	Description	Total
1	1550 yards of common fill for civil area of the project only. This excludes the building pad.	\$ 85,250.00
Sub-total		\$ 85,250.00
General Conditions		\$ 4,262.50
Sub-total		\$ 89,512.50
Insurance		\$ 1,790.25
Bond		\$ 1,790.25
Sub-total		\$ 93,093.00
Mark up		\$ 13,963.95
<b>Total</b>		<b>\$ 107,056.95</b>

Does Proposed Change involve a change in Contract Sum?	<input type="checkbox"/> No	<input checked="" type="checkbox"/> Yes	[Increase / Decrease]	<u>\$107,056.95</u>
Does Proposed Change involve a change in Contract Time?	<input type="checkbox"/> No	<input checked="" type="checkbox"/> Yes	[Increase / Decrease]	Days <u>10</u>

JC Commercial  
**CONTRACTOR**  
 1801 Lakepointe Drive, Suite #129  
 Lewisville, TX 75057

Architect

By: Scott Arthur  
 Signature: Scott Arthur  
 Date: 3/19/2020

By: \_\_\_\_\_  
 Signature: \_\_\_\_\_  
 Date: \_\_\_\_\_

**Page Technical Pkg. No.**  
 10/2016  
**Project No.** 16036  
**Date** 11/12/2016  
**Sheet No.** 16036-001

**OWNER:**  
 Town of Addison  
 4545 Jimmy Doolittle Drive  
 Addison, TX 75001  
**DESIGNED BY:**  
 James M. Hester  
 11100 Old Lane  
 Dallas, TX 75244  
**CHECKED BY:**  
 James M. Hester  
 11100 Old Lane  
 Dallas, TX 75244  
**DATE:** 11/12/2016

# Town of Addison Airport Customs and Border Protection Facility 4545 Jimmy Doolittle Drive Addison, TX 75001

REVISION HISTORY

NO.	DATE	DESCRIPTION
1	11/12/2016	ISSUED FOR PERMITS

CP 16036 (CROSS SECTIONS 1)

**XSEC6**

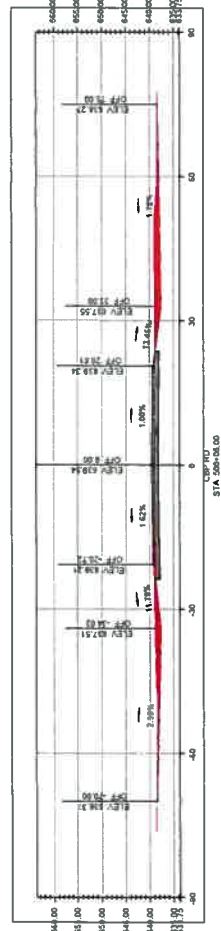

**EARTHWORK**

151.37	1.18
51.74	1.18

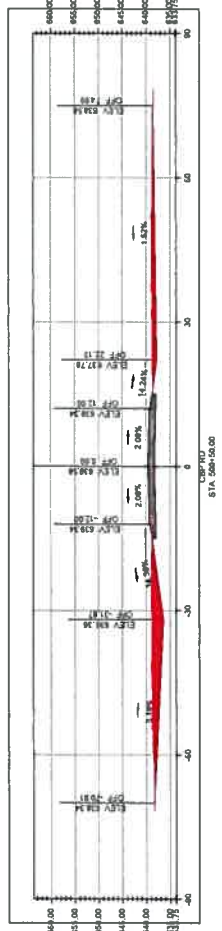

**EARTHWORK**

151.37	2.31
51.74	2.31

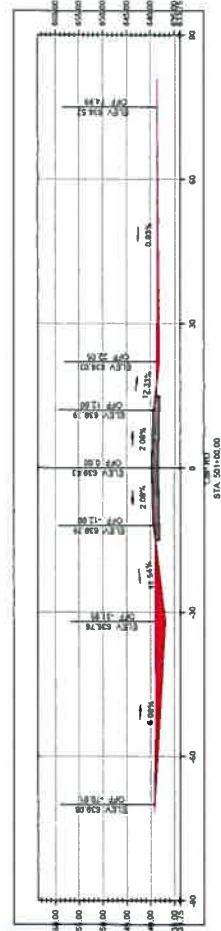

**EARTHWORK**

151.37	1.18
51.74	1.18

Page Development of Plans, Inc.  
14414 West Loop South, Suite 300  
Houston, Texas 77030  
Tel: 281.411.1000  
Fax: 281.411.1001

**PROJECT DATA**  
PROJECT NO. 2014000001  
SHEET NO. 101  
DATE 10/10/14

**CLIENT**  
TOWN OF ADDISON  
4545 JIMMY DOOLITTLE DRIVE  
ADDISON, TX 75001  
714.394.3100

**DESIGNED BY**  
KIMBERLY BURNETT  
714.394.3100

**CHECKED BY**  
JAMES W. BURNETT  
714.394.3100

**APPROVED BY**  
JAMES W. BURNETT  
714.394.3100

# Town of Addison Airport Customs and Border Protection Facility Addison, TX 75001

### REVISION HISTORY

NO.	DESCRIPTION	DATE
1	ISSUED FOR PERMITS	08/11/14
2	ISSUED FOR PERMITS	09/05/14
3	ISSUED FOR PERMITS	10/10/14

### OPEN ROAD CROSS SECTIONS 2

SECTION	DATE
SECTION 1	08/11/14
SECTION 2	09/05/14
SECTION 3	10/10/14

### XSEC7

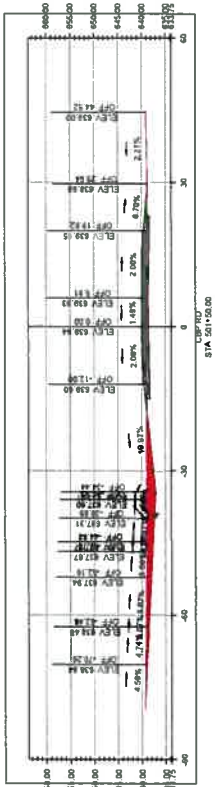

GRADE	PERCENT
2.58%	2.58%

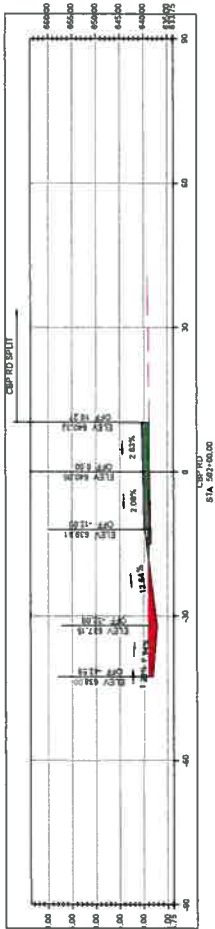

GRADE	PERCENT
2.58%	2.58%

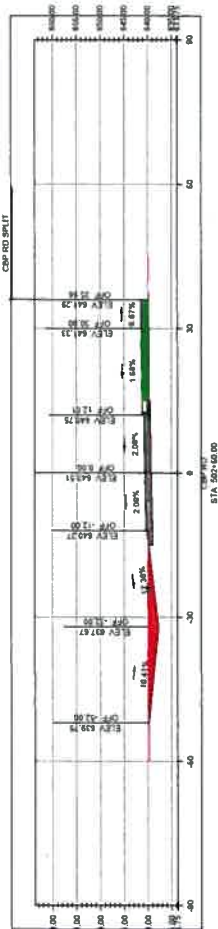

GRADE	PERCENT
2.58%	2.58%





**Paul Schweitzer & Associates, Inc.**  
11445 Lyndon B. Johnson Freeway, Suite 200  
Dallas, Texas 75243  
Tel: 214 341 5044  
Fax: 214 341 5044  
www.psa-inc.com

**PROFESSIONAL ENGINEER**  
**DRYden Engineering**  
11445 Lyndon B. Johnson Freeway, Suite 200  
Dallas, Texas 75243  
Tel: 214 341 5044  
Fax: 214 341 5044  
www.dryden-engineering.com

**REGISTERED LAND SURVEYOR**  
**Wendell C. Dyer**  
11445 Lyndon B. Johnson Freeway, Suite 200  
Dallas, Texas 75243  
Tel: 214 341 5044  
Fax: 214 341 5044  
www.wendellcoadyer.com

**Town of Addison Airport  
Customs and Border Protection Facility**  
4545 Jimmy Doolittle Drive  
Addison, TX 75001

REVISION HISTORY

NO.	DESCRIPTION	DATE

CIP ROAD SPLIT CROSS SECTION 1  
DATE: 11/21/17  
SCALE: 1" = 4'-0"

**XSEC10**

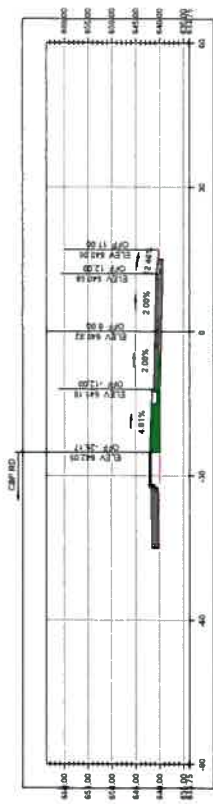
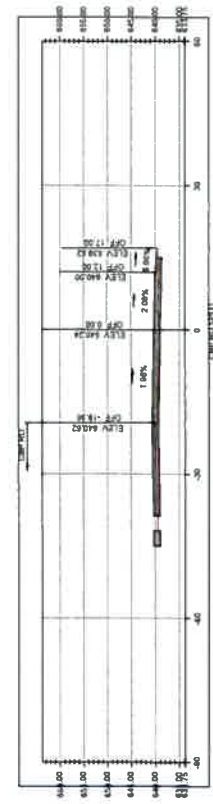
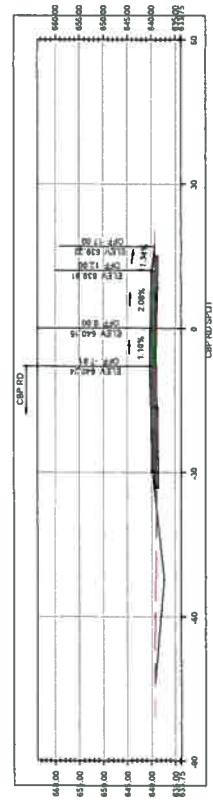

THESE DRAWINGS WERE PREPARED BY THE CONSULTING ENGINEER AND SURVEYOR AND THEY ARE NOT TO BE USED FOR ANY OTHER PROJECT WITHOUT THE WRITTEN PERMISSION OF THE CONSULTING ENGINEER AND SURVEYOR.

**CIP ROAD CUT CROSS SECTIONS**

SECTION NO.	11
DATE	11/11/25
PROJECT	ADDISON AIRPORT
CITY	ADDISON, TX
SCALE	AS SHOWN
DESIGNED BY	PROJECT ENGINEER
CHECKED BY	PROJECT ENGINEER

**XSECC11**

PROJECT NO. **25001001**

NO.	DESCRIPTION	DATE

**Town of Addison Airport  
Customs and Border Protection Facility  
4545 Jimmy Doolittle Drive  
Addison, TX 75001**

**PREPARED BY:** PROJECT ENGINEER/ESTIMATOR/QUANTITY SURVEYOR  
**DESIGNED BY:** PROJECT ENGINEER  
**CHECKED BY:** PROJECT ENGINEER

**DATE:** 11/11/25

**PROJECT:** ADDISON AIRPORT  
**CITY:** ADDISON, TX  
**SCALE:** AS SHOWN

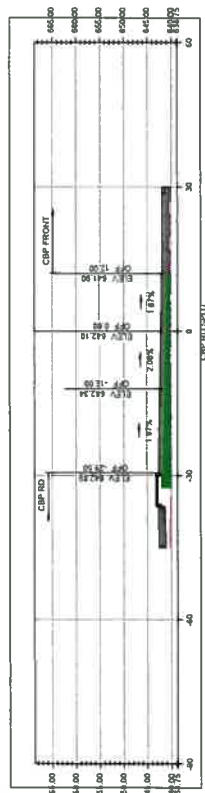
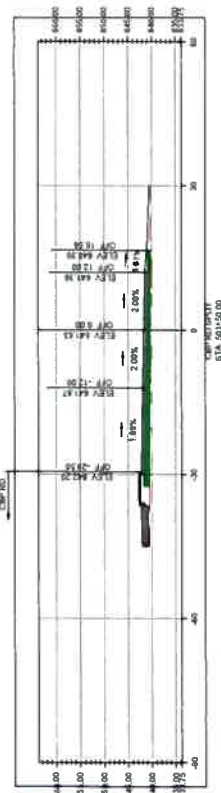

**EARTHWORK**

ITEM	AMOUNT	UNIT

**EARTHWORK**

ITEM	AMOUNT	UNIT



# Town of Addison Airport Customs and Border Protection Facility 4545 Jimmy Doolittle Drive Addison, TX 75001

**OWNER:**  
 Town of Addison  
 4545 Jimmy Doolittle Drive  
 Addison, TX 75001  
 972-383-1100

**DESIGNER:**  
 Parsons Brinckerhoff  
 1000 North Central Expressway  
 Suite 1500  
 Richardson, TX 75080  
 972-383-1100

**DATE:**  
 10/20/2011

**PROJECT NO.:**  
 TOWNSHIP OF ADDISON AIRPORT  
 CUSTOMS AND BORDER PROTECTION  
 FACILITY

**CLIENT NO.:**  
 10000011

**DATE:**  
 10/20/2011

Page/

CIP FRONT CROSS SECTIONS 1

XSECI2

REVISION HISTORY:	DATE	BY	REVISION

EARTHWORK	PER. (CIP)

EARTHWORK	PER. (CIP)

EARTHWORK	PER. (CIP)

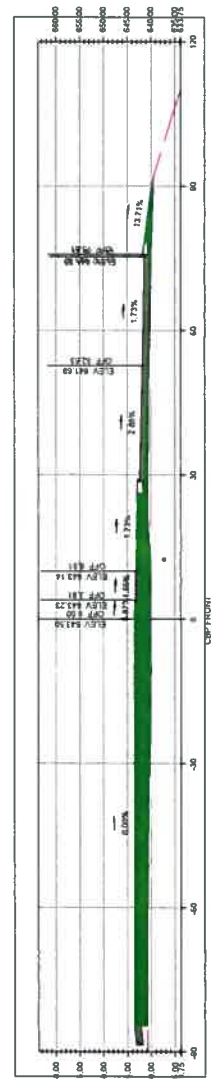
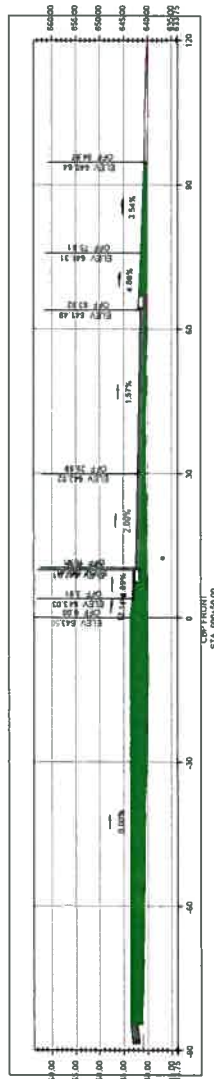
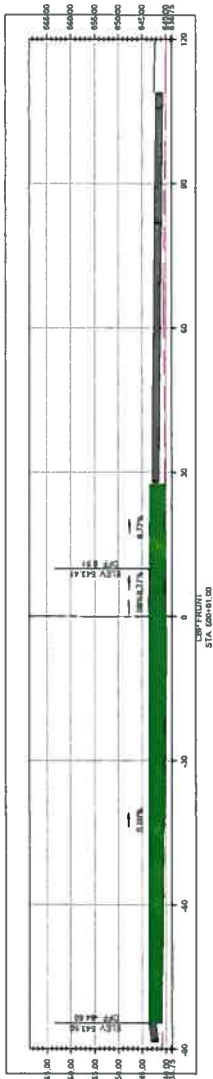

Small text at the bottom of the page, likely containing project details and contact information.



Addison Airport  
FIS Landside Earthwork

LANDSCAPING		Original Survey Takeoff Calculations		JC Survey Takeoff Calculations		
Location	Area (SF)	Average Depth (FT)	Volume (CY)	Average Depth (FT)	Volume (CY)	Volume w/Compaction (CY)
1	1752.00	1.04	67.48	1.86	120.69	168.97
2	1929.00	0.78	55.73	1.21	86.45	121.03
3	4719.00	0.38	66.42	0.04	6.99	9.79
4	2659.00	0.54	53.18	0.57	56.13	75.50
5	2014.00	0.62	46.25	0.55	41.03	57.44
6	4393.00	0.09	14.64	0.81	131.79	184.51
7	4192.00	-0.84	-130.42	0.10	15.53	21.74
8	4069.00	-0.18	-27.13	0.12	18.08	25.32
9	4035.00	-0.28	-41.84	0.01	1.49	2.09
10	857.00	1.23	39.04	1.33	42.22	59.10
11	7647.00	-0.15	-42.48	-0.06	0.00	0.00
12	627.00	2.56	59.45	2.56	59.45	83.23
13	5828.00	0.65	140.30	0.45	97.13	135.99
14	3265.00	0.22	26.60	0.27	32.65	45.71
33	956.00	2.32	82.15	3.07	108.70	152.18
34	540.00	2.43	48.60	2.43	48.60	68.04
35	3354.00	0.39	48.45	0.72	89.44	125.22
		Subtotal =	506.41		956.38	1338.93
		Concrete Volume (CY) =	0.00		0.00	0.00
		Site Stripping (CY) =	0.00		0.00	332.68
		Total Volume (CY) =	506.41		956.38	1671.61

Corrected

FIRE LANE		Original Survey Takeoff Calculations		JC Survey Takeoff Calculations		
Location	Area (SF)	Average Depth (FT)	Volume (CY)	Average Depth (FT)	Volume (CY)	Volume w/Compaction (CY)
15	1344.00	2.06	102.54	2.99	148.84	208.37
16	1321.00	2.02	98.83	3.32	162.43	227.41
17	2649.00	1.98	194.26	2.18	213.88	299.44
20	2321.00	1.45	124.65	1.79	153.87	215.42
22	1939.00	1.51	108.44	1.60	114.90	160.87
24	2767.00	2.54	260.30	1.94	198.81	278.34
26	3586.00	1.48	196.57	1.51	200.55	280.77
27	4083.00	0.72	108.88	0.63	95.27	133.38
28	3953.00	0.63	92.24	0.84	122.98	172.18
29	2625.00	0.39	37.92	0.96	93.33	130.67
		Subtotal =	1324.62		1504.88	2106.83
		Concrete Volume (CY) =	-659.78		-659.78	-659.78
		Site Stripping (CY) =	0.00		0.00	246.19
		Total Volume (CY) =	664.84		845.10	1693.24

SIDEWALK		Original Survey Takeoff Calculations		JC Survey Takeoff Calculations		
Location	Area (SF)	Average Depth (FT)	Volume (CY)	Average Depth (FT)	Volume (CY)	Total Volume w/Compaction (CY)
30	2645.00	2.41	236.09	2.41	236.09	330.53
		Subtotal =	236.09		236.09	330.53
		Concrete Volume (CY) =	-32.33		-32.33	-32.33
		Site Stripping (CY) =	0.00		0.00	0.00
		Total Volume (CY) =	203.76		203.76	298.20

PARKING AREA		Original Survey Takeoff Calculations		JC Survey Takeoff Calculations		
Location	Area (SF)	Average Depth (FT)	Volume (CY)	Average Depth (FT)	Volume (CY)	Volume w/Compaction (CY)
18	1431.00	1.14	60.42	1.26	66.78	93.49
19	1364.00	2.35	118.72	2.35	118.72	166.21
21	1644.00	2.09	127.26	2.17	132.13	184.98
23	545.00	2.76	55.71	2.63	53.09	74.32
25	2581.00	2.16	206.48	2.18	208.39	291.75
		Subtotal =	568.59		579.11	810.75
		Concrete Volume (CY) =	-187.73		-187.73	-187.73
		Site Stripping (CY) =	0.00		0.00	70.05
		Total Volume (CY) =	380.86		391.38	693.07

WEST FILL		Original Survey Takeoff Calculations		JC Survey Takeoff Calculations		
Location	Area (SF)	Average Depth (FT)	Volume (CY)	Average Depth (FT)	Volume (CY)	Volume w/Compaction (CY)
31	3812.00	0.00	0.00	2.69	379.79	531.70
		Subtotal =	0.00		379.79	531.70
		Concrete Volume (CY) =	0.00		0.00	0.00
		Site Stripping (CY) =	0.00		0.00	0.00
		Total Volume (CY) =	0.00		379.79	531.70

EARTHWORK VOLUME SUMMARY				
LOCATION	Original Survey Takeoff VOLUME (CY)	JC Survey Average End		JC Survey Takeoff w/Compaction VOLUME (CY)
		Area Method VOLUME (CY)	JC Survey Takeoff VOLUME (CY)	
LANDSCAPING =	506.41		956.38	1671.61
FIRE LANE =	664.84		845.10	1693.24
SIDEWALK =	203.76		203.76	298.20
PARKING AREA =	380.86		391.38	693.07
FOUNDATION =	0.00		0.00	1633.92
WEST FILL =	0.00		379.79	531.70
<b>TOTAL =</b>	<b>1755.87</b>	<b>1957.00</b>	<b>2776.40</b>	<b>6521.74</b>
CONTRACT EMBANKMENT QUANTITY (CY) =		1006.00	1006.00	1006.00
DIFFERENCE IN VOLUME (CY) =		951.00	1770.40	5515.74

## ITEM P-152 EXCAVATION, SUBGRADE, AND EMBANKMENT

## DESCRIPTION

**152-1.1** This item covers excavation, disposal, placement, and compaction of all materials within the limits of the work required to construct safety areas, runways, taxiways, aprons, and intermediate areas as well as other areas for drainage, building construction, parking, or other purposes in accordance with these specifications and in conformity to the dimensions and typical sections shown on the plans.

**152-1.2 CLASSIFICATION.** All material excavated shall be classified as defined below:

**a. Unclassified Excavation.** Unclassified excavation shall consist of the excavation and disposal of all material, regardless of its nature which is not otherwise classified and paid for under one of the following items.

~~**b. Rock Excavation.** Rock excavation shall include all solid rock in ledges, in bedded deposits, in unstratified masses, and conglomerate deposits which are so firmly cemented they cannot be removed without blasting or using rippers. All boulders containing a volume of more than 1/2 cubic yard will be classified as "rock excavation."~~

~~**c. Muck Excavation.** Muck excavation shall consist of the removal and disposal of deposits or mixtures of soils and organic matter not suitable for foundation material. Muck shall include materials that will decay or produce subsidence in the embankment. It may consist of decaying stumps, roots, logs, humus, or other material not satisfactory for incorporation in the embankment.~~

~~**d. Drainage Excavation.** Drainage excavation shall consist of all excavation made for the primary purpose of drainage and includes drainage ditches, such as intercepting, inlet or outlet ditches; temporary levee construction; or any other type as shown on the plans.~~

~~**e. Borrow Excavation.** Borrow excavation shall consist of approved material required for the construction of embankments or for other portions of the work in excess of the quantity of usable material available from required excavations. Borrow material shall be obtained from areas designated by the Engineer within the limits of the airport property but outside the normal limits of necessary grading, or from areas outside the airport boundaries.~~

**152-1.3 Unsuitable Excavation.** Any material containing vegetable or organic matter, such as muck, peat, organic silt, or sod shall be considered unsuitable for use in embankment construction. Material, suitable for topsoil may be used on the embankment slope when approved by the Engineer. ***Material not considered by the Engineer to be suitable for use on the embankment slope shall be disposed of off-site or as directed by the Engineer. Undercutting of material unsatisfactory for subgrade foundation, roads, shoulders, or areas intended for turfing shall be considered unsuitable excavation and shall be excavated to the depth specified by the Engineer below the subgrade.***

## CONSTRUCTION METHODS

**152-2.1 General.** ~~Before beginning excavation, grading, and embankment operations in any area, the area shall be completely cleared and grubbed in accordance with Item P-151.~~

The suitability of material to be placed in embankments shall be subject to approval by the Engineer. All unsuitable material shall be disposed of in waste areas shown on the plans. All waste areas shall be graded to allow positive drainage of the area and of adjacent areas. The surface elevation of waste areas shall not extend above the surface elevation of adjacent usable areas of the airport, unless specified on the plans or approved by the Engineer.

When the Contractor's excavating operations encounter artifacts of historical or archaeological significance, the operations shall be temporarily discontinued and the Engineer notified per subsection 70-20 ~~of the General Provisions~~. At the direction of the Engineer, the Contractor shall excavate the site in such a manner as to preserve the artifacts encountered and allow for their removal. Such excavation will be paid for as extra work.

Those areas outside of the limits of the pavement areas where the top layer of soil material has become compacted by hauling or other Contractor activities shall be scarified and disked to a depth of 4 inches, to loosen and pulverize the soil.

If it is necessary to interrupt existing surface drainage, sewers or under-drainage, conduits, utilities, or similar underground structures, the Contractor shall be responsible for and shall take all necessary precautions to preserve them or provide temporary services. When such facilities are encountered, the Contractor shall notify the Engineer, who shall arrange for their removal if necessary. The Contractor, at his or her expense, shall satisfactorily repair or pay the cost of all damage to such facilities or structures that may result from any of the Contractor's operations during the period of the contract.

**152-2.2 EXCAVATION.** No excavation shall be started until the work has been staked out by the Contractor and the Engineer has obtained from the Contractor the survey notes of the elevations and measurements of the ground surface. **All areas to be excavated shall be stripped of vegetation and topsoil. Topsoil shall be stockpiled for future use in areas designated on the plans or by the Engineer. All suitable excavated material shall be used in the formation of embankment, subgrade, or other purposes shown on the plans.** All unsuitable material shall be disposed of as *described in paragraph 152-1.3 shown on the plans.*

When the volume of the excavation exceeds that required to construct the embankments to the grades indicated, the excess shall be used to grade the areas of ultimate development or disposed as directed by the Owner. When the volume of excavation is not sufficient for constructing the embankments to the grades indicated, the deficiency shall be obtained from borrow areas.

The grade shall be maintained so that the surface is well drained at all times. When necessary, temporary drains and drainage ditches shall be installed to intercept or divert surface water that may affect the work.

**a. Selective Grading.** When the quality of material varies ~~selective grading is indicated on the plans,~~ the more suitable material designated by the Engineer shall be used in constructing the embankment or in capping the pavement subgrade. If, at the time of excavation, it is not possible to place this material in its final location, it shall be stockpiled in approved areas. ~~so that it can be measured for payment as specified in paragraph 152-3.3. .~~ *Selective grading will not be measured for separate payment but will be considered subsidiary to "Unclassified Excavation".*

**b. Undercutting.** Rock, shale, hardpan, loose rock, boulders, or other material unsatisfactory for safety areas, subgrades, roads, shoulders, or any areas intended for turf shall be excavated to a minimum depth of 12 inches below the subgrade or to the depth specified by the Engineer. Muck, peat, matted roots, or other yielding material, unsatisfactory for subgrade foundation, shall be removed to the depth specified. Unsuitable materials shall be disposed off the airport. The cost is incidental to this item *disposed of as directed in paragraph 152-1.3.* This excavated material shall be paid for at the contract unit price per cubic yard for **Unsuitable Excavation**. The excavated area shall be backfilled with suitable material obtained from the grading operations or borrow areas and compacted to specified densities. The necessary backfill will constitute a *necessary part of Unsuitable Excavation* ~~part of the embankment~~. Where rock cuts are made, backfill with select material. Any pockets created in the rock surface shall be drained *as directed by the Engineer in accordance with the details shown on the plans.*

**c. Overbreak.** Overbreak, including slides, is that portion of any material displaced or loosened beyond the finished work as planned or authorized by the Engineer. All overbreak shall be graded or removed by the Contractor and disposed of as directed by the Engineer. The Engineer shall determine if the displacement of such material was unavoidable and his or her decision shall be final. Payment will not be

made for the removal and disposal of overbreak that the Engineer determines as avoidable. Unavoidable overbreak will be classified as "Unclassified Excavation."

**d. Removal of Utilities.** The removal of *some* existing structures and utilities required to permit the orderly progress of work *may* will be accomplished by someone other than the Contractor; for example, the utility unless otherwise shown on the plans. All existing foundations shall be excavated at least 2 feet below the top of subgrade or as indicated on the plans, and the material disposed of as directed by the Engineer. All foundations thus excavated shall be backfilled with suitable material and compacted as specified. *All work associated with the excavation, removal, backfill, disposal, and/or stockpiling of existing structures and culverts be considered subsidiary to "Unclassified Excavation".*

**e. Compaction Requirements.** The subgrade under areas to be paved shall be compacted to a depth of 8" and to a density of not less than 95 percent of the maximum density as determined by ASTM D1557. The material to be compacted shall be within  $\pm 2\%$  of optimum moisture content before being rolled to obtain the prescribed compaction (except for expansive soils).

The in-place field density shall be determined in accordance with ASTM D6938 using Procedure A, the direct transmission method, and ASTM D6938 shall be used to determine the moisture content of the material. The machine shall be calibrated in accordance with ASTM D6938. Stones or rock fragments larger than 4 inches in their greatest dimension will not be permitted in the top 6 inches of the subgrade. The finished grading operations, conforming to the typical cross-section, shall be completed and maintained at least 1,000 feet ahead of the paving operations or as directed by the Engineer.

All loose or protruding rocks on the back slopes of cuts shall be pried loose or otherwise removed to the slope finished grade line. All cut-and-fill slopes shall be uniformly dressed to the slope, cross-section, and alignment shown on the plans or as directed by the Engineer.

Blasting shall not be allowed.

**f. Proof Rolling.** After compaction is completed, the subgrade area shall be proof rolled with heavy pneumatic-tired roller having four or more tires abreast, each tire loaded to a minimum of 30,000 pounds and inflated to a minimum of 125 psi in the presence of the independent QC Engineer. Apply a minimum of 50% coverage, or as specified by the Engineer, to all paved areas. A coverage is defined as the application of one tire print over the designated area. Soft areas of subgrade that deflect more than 1 inch or show permanent deformation greater than 1 inch shall be removed and replaced with suitable material or reworked to conform to the moisture content and compaction requirements in accordance with these specifications.

**152-2.3 BORROW EXCAVATION.** Borrow areas within the airport property are indicated on the plans. Borrow excavation shall be made only at these designated locations and within the horizontal and vertical limits as staked or as directed by the Engineer.

When borrow sources are outside the boundaries of the airport property, it shall be the Contractor's responsibility to locate and obtain the borrow sources, subject to the approval of the Engineer. The Contractor shall notify the Engineer at least 15 days prior to beginning the excavation so necessary measurements and tests can be made. All borrow pits shall be opened up to expose the various strata of acceptable material to allow obtaining a uniform product. All unsuitable material shall be disposed of by the Contractor. Borrow pits shall be excavated to regular lines to permit accurate measurements, and they shall be drained and left in a neat, presentable condition with all slopes dressed uniformly.

**152-2.4 DRAINAGE EXCAVATION.** Drainage excavation shall consist of excavating for drainage ditches such as intercepting; inlet or outlet ditches; for temporary levee construction; or for any other type as designed or as shown on the plans. The work shall be performed in sequence with the other construction. Intercepting ditches shall be constructed prior to starting adjacent excavation operations. All satisfactory material shall be placed in embankment fills; unsuitable material shall be placed in designated waste areas

or as directed by the Engineer. All necessary work shall be performed true to final line, elevation, and cross-section. The Contractor shall maintain ditches constructed on the project to the required cross-section and shall keep them free of debris or obstructions until the project is accepted.

**152-2.5 PREPARATION OF EMBANKMENT AREA.** Where an embankment is to be constructed to a height of 4 feet or less, all sod and vegetative matter shall be removed from the surface upon which the embankment is to be placed. The cleared surface shall be broken up by plowing or scarifying to a minimum depth of 6 inches and shall then be compacted as indicated in paragraph 152-2.6.

When the height of fill is greater than 4 feet, sod not required to be removed shall be thoroughly disked and recompacted to the density of the surrounding ground before construction of embankment.

Sloped surfaces steeper than one (1) vertical to four (4) horizontal shall be plowed, stepped, benched, or broken up so that the fill material will bond with the existing material. When the subgrade is part fill and part excavation or natural ground, the excavated or natural ground portion shall be scarified to a depth of 12 inches and compacted as specified for the adjacent fill.

**No direct payment shall be made for the work performed under this section.** The necessary clearing and grubbing and the quantity of excavation removed will be paid for under the respective items of work.

**152-2.6 FORMATION OF EMBANKMENTS.** Embankments shall be formed in successive horizontal layers of not more than 8 inches in loose depth for the full width of the cross-section, unless otherwise approved by the Engineer.

The layers shall be placed, to produce a soil structure as shown on the typical cross-section or as directed by the Engineer. Materials such as brush, hedge, roots, stumps, grass and other organic matter, shall not be incorporated or buried in the embankment.

Earthwork operations shall be suspended at any time when satisfactory results cannot be obtained because of rain, freezing, or other unsatisfactory weather conditions in the field. Frozen material shall not be placed in the embankment nor shall embankment be placed upon frozen material. Material shall not be placed on surfaces that are muddy, frozen, or contain frost. The Contractor shall drag, blade, or slope the embankment to provide surface drainage at all times.

The material in each layer shall be within  $\pm 2\%$  of optimum moisture content before rolling to obtain the prescribed compaction. To achieve a uniform moisture content throughout the layer, the material shall be moistened or aerated as necessary. Samples of all embankment materials for testing, both before and after placement and compaction, will be taken for each 1000SY of material placed. Based on these tests, the Contractor shall make the necessary corrections and adjustments in methods, materials or moisture content to achieve the specified embankment density.

Rolling operations shall be continued until the embankment is compacted to not less than 95% of maximum density for noncohesive soils, and 90% of maximum density for cohesive soils as determined by ASTM D1557. Under all areas to be paved, the embankments shall be compacted to a depth of 8" and to a density of not less than 95 percent of the maximum density as determined by ASTM D1557.

On all areas outside of the pavement areas, no compaction will be required on the top 4 inches.

The in-place field density shall be determined in accordance with ASTM D6938 using Procedure A, the direct transmission method, and ASTM D6938 shall be used to determine the moisture content of the material. The machine shall be calibrated in accordance with ASTM D6938. *The Engineer shall perform all density tests.*

Compaction areas shall be kept separate, and no layer shall be covered by another layer until the proper density is obtained.



During construction of the embankment, the Contractor shall route all construction equipment evenly over the entire width of the embankment as each layer is placed. Layer placement shall begin in the deepest portion of the embankment fill. As placement progresses, the layers shall be constructed approximately parallel to the finished pavement grade line.

When rock and other embankment material are excavated at approximately the same time, the rock shall be incorporated into the outer portion of the embankment and the other material shall be incorporated under the future paved areas. Stones or fragmentary rock larger than 4 inches in their greatest dimensions will not be allowed in the top 6 inches of the subgrade. Rockfill shall be brought up in layers as specified or as directed by the Engineer and the finer material shall be used to fill the voids with forming a dense, compact mass. Rock or boulders shall not be disposed of outside the excavation or embankment areas, except at places and in the manner designated on the plans or by the Engineer.

When the excavated material consists predominantly of rock fragments of such size that the material cannot be placed in layers of the prescribed thickness without crushing, pulverizing or further breaking down the pieces, such material may be placed in the embankment as directed in layers not exceeding 2 feet in thickness. Each layer shall be leveled and smoothed with suitable equipment by distribution of spalls and finer fragments of rock. The layer shall not be constructed above an elevation 4 feet below the finished subgrade.

**There will be no separate measurement of payment for compacted embankment.** All costs incidental to placing in layers, compacting, discing, watering, mixing, sloping, and other operations necessary for construction of embankments will be included in the contract price for excavation, borrow, or other items.

***Imported material for fill or backfill under pavements shall be free of rock fragments greater than 4 inches in size, organic matter, and other deleterious materials. The material should also have a liquid limit less than 60 and plasticity index at least 16. The fine content (percent passing a No. 200 sieve) of the material should be 45 percent or more.***

**152-2.7 FINISHING AND PROTECTION OF SUBGRADE.** After the subgrade is substantially complete, the Contractor shall remove any soft or other unstable material over the full width of the subgrade that will not compact properly. All low areas, holes or depressions in the subgrade shall be brought to grade with suitable select material. Scarifying, blading, rolling and other methods shall be performed to provide a thoroughly compacted subgrade shaped to the lines and grades shown on the plans.

Grading of the subgrade shall be performed so that it will drain readily. The Contractor shall protect the subgrade from damage and limit hauling over the finished subgrade to only traffic essential for construction purposes. All ruts or rough places that develop in the completed subgrade shall be graded and recompacted.

No subbase, base, or surface course shall be placed on the subgrade until the subgrade has been approved by the Engineer.

**152-2.8 HAUL.** All hauling will be considered a necessary and incidental part of the work. The Contractor shall include the cost in the contract unit price for the pay of items of work involved. No payment will be made separately or directly for hauling on any part of the work.

**152-2.9 TOLERANCES.** In those areas upon which a subbase or base course is to be placed, the top of the subgrade shall be of such smoothness that, when tested with a 12-foot straightedge applied parallel and at right angles to the centerline, it shall not show any deviation in excess of 1/2 inch, or shall not be more than 0.05 feet from true grade as established by grade hubs. Any deviation in excess of these amounts shall be corrected by loosening, adding, or removing materials; reshaping; and recompacting.

On safety areas, intermediate and other designated areas, the surface shall be of such smoothness that it will not vary more than 0.10 feet from true grade as established by grade hubs. Any deviation in excess of this amount shall be corrected by loosening, adding or removing materials, and reshaping.

**152-2.10 TOPSOIL.** When topsoil is specified or required as shown on the plans or under Item T-905, it shall be salvaged from stripping or other grading operations. The topsoil shall meet the requirements of Item T-905. If, at the time of excavation or stripping, the topsoil cannot be placed in its final section of finished construction, the material shall be stockpiled at approved locations. Stockpiles shall not be placed within **400** feet of runway pavement or **100** feet of taxiway pavement and shall not be placed on areas that subsequently will require any excavation or embankment fill. If, in the judgment of the Engineer, it is practical to place the salvaged topsoil at the time of excavation or stripping, the material shall be placed in its final position without stockpiling or further rehandling.

Upon completion of grading operations, stockpiled topsoil shall be handled and placed as directed, or as required in Item T-905.

No direct payment will be made for topsoil under Item P-152. The quantity removed and placed directly or stockpiled shall be paid for at the contract unit price per cubic yard for "Unclassified Excavation."

When stockpiling of topsoil and later rehandling of such material is directed by the Engineer, the material so rehandled shall be paid for at the contract unit price per cubic yard for "topsoiling," as provided in Item T-905.

#### METHOD OF MEASUREMENT

**152-3.1** The quantity of excavation to be paid for shall be the number of cubic yards measured in its original position. Measurement shall not include the quantity of materials excavated without authorization beyond normal slope lines, or the quantity of material used for purposes other than those directed.

*Measurement of excavation/embankment shall be based on **plan quantities**. These quantities are believed to be correct and shall be utilized for final excavation quantity payment not withstanding any adjustments to the project by written direction of the Engineer. Should the contractor find discrepancies and/or errors, he/she shall bring the discrepancy and/or error to the attention of the Engineer immediately and corrections shall be made to the quantity of excavation to be paid for by change order. It is expressly understood by the contractor that upon disturbance of the existing ground and no notification to the engineer of possible errors, that the contractor accepts as final payment the quantities of excavation as detailed on the plans and laid out in the proposal. **No adjustment has been made to the plan quantities for the construction or demolition of existing drainage structures. The Contractor shall make his own determination as to the amount of unsuitable excavated material which may be encountered and the resulting additional borrow material required for the construction of the embankment. There will be no adjustment for additional embankment required to construct the project if the excavated material is deemed unsuitable.***

~~**152-3.2** Borrow material shall be paid for on the basis of the number of cubic yards measured in its original position at the borrow pit.~~

~~**152-3.3** Stockpiled material shall be paid for on the basis of the number of cubic yards measured in the stockpiled position as soon as the material has been stockpiled.~~

**152-3.2** For payment specified by the cubic yard, measurement for all excavation/embankment shall be computed by the average end area method. The end area is that bound by the original ground line established by field cross-sections and the final theoretical pay line established by **Excavation/embankment cross-sections shown on the plans, subject to verification by the Engineer. After completion of all excavation/embankment operations and prior to the placing of base or subbase material, the final excavation/embankment shall be verified by the Engineer by means of field cross-sections taken randomly at intervals not exceeding 500 linear feet.**

*In cut sections, the additional cut required to construct the topsoil layer to the plan grade has not been measured and will not be measured for separate payment but will be subsidiary to "Unclassified Excavation". In fill sections, the additional fill required to replace the stripped material has not been measured and will not be measured for payment but will be subsidiary to "Unclassified Excavation".*

**No allowance has been made in the measurement for shrink/swell. The Contractor shall make his own determination as to the amount of shrink/swell involved in the construction of the embankment.**

*The Contractor shall make his own determination as to the suitability of the excavated material to be placed in embankments and the resulting additional off-site material required for the construction of the embankment. Additional off-site material required for the formation of embankment shall not be measured for separate payment but shall be considered subsidiary to "Unclassified Excavation".*

**152-3.6** *Unsuitable excavation shall be measured from the surface of the ground, after stripping has been accomplished, or from the bottom of the planned excavation, to the depth of the excavation as directed by the Engineer. Measurements will be taken by the Engineer, and the volume of excavation will be calculated by the average end area method. The necessary refilling of unsuitable areas will not be measured for separate payment but will be subsidiary to "Unsuitable Excavation". Only that amount of excavation directed by the Engineer will be measured for payment.*

#### **BASIS OF PAYMENT**

**152-4.1** "Unclassified excavation" payment shall be made at the contract unit price per cubic yard. This price shall be full compensation for furnishing all materials, labor, equipment, tools, and incidentals necessary to complete the item.

Payment will be made under:

Item P-152-4.1	Unclassified Excavation – per Cubic Yard
Item P-152-4.2	Embankment – per Cubic Yard

#### **TESTING REQUIREMENTS**

ASTM D698	Standard Test Methods for Laboratory Compaction Characteristics of Soil Using Standard Effort (12,400 ft-lbf/ft <sup>3</sup> )
ASTM D1556	Standard Test Method for Density and Unit Weight of Soil in Place by the Sand-Cone Method
ASTM D1557	Standard Test Methods for Laboratory Compaction Characteristics of Soil Using Modified Effort (56,000 ft-lbf/ft <sup>3</sup> )
ASTM D2167	Standard Test Method for Density and Unit Weight of Soil in Place by the Rubber Balloon Method
ASTM D6938	Standard Test Methods for In-Place Density and Water Content of Soil and Soil-Aggregate by Nuclear Methods (Shallow Depth)

**END OF ITEM P-152**

---

## Stevanovic, Vladimir (Vlad)

---

**From:** Bunch, Kyle <kbunch@mooresupply.com>  
**Sent:** Monday, April 13, 2020 9:28 AM  
**To:** Juan Tobias  
**Subject:** Fw: Acorn

**Kyle Bunch**  
**Moore Supply Company**  
Phone: 817-784-2340  
Fax: 817-784-2335  
E-fax: 484-708-1921

---

**From:** Blake Lenamond <blenamond@dillardassoc.com>  
**Sent:** Monday, April 13, 2020 8:56 AM  
**To:** Bunch, Kyle <kbunch@mooresupply.com>  
**Subject:** Acorn

**\*NOTE: THIS IS AN EXTERNAL EMAIL\***

Kyle,

Acorn orders are non returnable and sometimes non cancelable once sent off into production since these are made to order based on signed submittals with desired options.

**Blake Lenamond**  
Dillard Associates  
214.843.2218 cell

1504 Selene Dr, Carrollton TX 75006 (972.278.2000)  
6100 Tri County Parkway, Schertz TX 78154 (210.824.4881)



---

**IMPORTANT NOTICE:** This email was sent from outside of Hajoca Corporation. If you are not sure who the sender is then do not open attachments, click any links within this email, or enter credentials in any forms. If this email appears suspicious, please use the **Report Phishing button** to open an investigation into the email. You will be informed if the email is safe. If you are unsure of how to report, or are missing the Report Phishing button, please contact the Computer Help Desk using this [LINK](#) to open a ticket.

---

Confidentiality Notice: Information in this message, including any attachments, is intended only for the personal and confidential use of the recipient(s) above named. The information contained in this message may be privileged and confidential, may constitute a trade secret, may be subject to the attorney-client privilege and may otherwise be protected from disclosure. If you are not the intended recipient of this message, or an agent responsible for delivering it to an intended recipient, you are hereby notified that you have received this message in error, and that any review, dissemination, disclosure, distribution, or copying of this message is strictly prohibited. If you received this message in error, please notify the sender immediately, delete this message and destroy any hard copy print-outs. We have taken precautions to minimize the risk of transmitting software viruses, but we advise you to carry your own virus checks on any attachment to this message. We cannot accept liability for any loss or damage caused by software viruses.



**Proposal #17**

Project: <u>Addison Airport Customs and</u> <u>Border Protection Facility</u> Date: <u>4/14/2020</u> Attn: <u>Jeff Mechlem, Mitchell McAnally</u> <u>Will Butler, Vlad Stevanovic</u>	Customer: <u>Town of Addison</u> <u>5350 Bellline Road</u> <u>Dallas, Texas 75254</u> Architect: <u>Page Southerland Page</u> <u>1100 Louisiana Street, Suite One</u> <u>Houston, Texas 77002</u>
---	--

This Proposal contains an itemized quotation for changes in the Contract Sum and/or Contract Time in response to proposed modifications to the Contract Documents based on RFI 89.

Item	Description	Total
1	Install and provide new WC/Lavatory combo unit per RFI 89.	\$ 2,620.00
	Sub-total	\$ 2,620.00
	General Conditions	\$ 131.00
	Sub-total	\$ 2,751.00
	Insurance	\$ 55.02
	Bond	\$ 55.02
	Sub-total	\$ 2,861.04
	Mark up	\$ 429.16
	<b>Total</b>	<b>\$ 3,290.20</b>

Does Proposed Change involve a change in Contract Sum?	<input type="checkbox"/> No	<input checked="" type="checkbox"/> Yes	[Increase / Decrease] <span style="float: right;">\$3,290.20</span>
Does Proposed Change involve a change in Contract Time?	<input type="checkbox"/> No	<input checked="" type="checkbox"/> Yes	[Increase / Decrease] <span style="float: right;">Days 10</span>

<b>JC Commercial</b> CONTRACTOR 1801 Lakepointe Drive, Suite #129 Lewisville, TX 75057	<b>Page Southerland Page</b> Architect 1100 Louisiana Street, Suite One Houston, Texas 77002
---	---

By: **Scott Arthur**  
 Signature: *Scott Arthur*  
 Date: 4/14/2020

By: \_\_\_\_\_  
 Signature: \_\_\_\_\_  
 Date: \_\_\_\_\_



1005 N Henderson Street  
Fort Worth, TX 76107  
817.900.2030

Change Order

---

Date: 4-13-20  
Job: Customs and Border Protection Facility  
To: ESTIMATING

---

Plumbing bid per RFI 89 and specs. Including the following fixtures;

- Install and provide new WC/Lavatory combo unit
- Change fixture type from fixture schedule to RFI 89
- 6-8 week lead time from the factory (non-stock item)
- Pricing based on normal work hours M-F, no expedited schedule
- MEP ceiling coordination meeting will be required prior to overhead piping
- Fixtures to be per schedule or equal.

**Base Bid Plumbing \$ 2,620.00**

**No tax included**

Exclusions;

No HVAC condensate. No Gas. NO BIM or ENGINEERED DRAWINGS. No rock excavation. No soil retainage/void systems. No taps, meters or fees. No coring, saw cut or XRAY in post tension slab. No saw cut or pour back. No pour back of existing leave outs. No painting of any pipe. No spoil haul off. No low voltage wiring if required. No sub-meter unless noted above, No backflow unless noted above. No DEMO or REPLACEMENT of ceilings, walls, wall coverings, floors, flooring, cabinets or any other item covering or encasing any plumbing to tie into or demo.

Thank You,  
Juan Tobias  
M-22558

Texas State Board of Plumbing Examiners  
929 E. 41<sup>st</sup>  
Austin, Tx 78751  
512-936-5200



**Penal-Ware® 1415 Series**  
15" Lav-Toilet Comby with Lavatory Multi-Sided Bowl



1415-CT-2-BP-04-FV



1415-AL-2-BP-04-FV-PHRF

Fixture May Show Some Available Options



Please visit [www.acorneng.com](http://www.acorneng.com) for most current specifications.

**15" Lav-Toilet Comby with Lavatory Multi-Sided Bowl**

**Fixture** is arranged to be installed on finished wall and serviced from an accessible pipe chase. Optional Wall Sleeve or Metal Template is recommended for all installations for required wall openings. Fixture is fabricated from 14 gage, type 304 stainless steel cabinet and toilet bowl and is seamless welded construction with a satin finish. The inside of the toilet bowl also has a satin finish. Cabinet interior is sound-deadened with fire-resistant material. There are no accessible voids or crevices where contraband can be concealed.

**Lavatory Multi-Sided Bowl** is 12-3/4" x 8-1/4" x 5" deep. Standard elbow waste outlet is 1-1/2" O.D. plain end.

**Optional Valve** may be an Air-Control pneumatically operated, pushbutton valve using atmospheric air. Pushbutton is vandal-resistant and requires less than 5 pounds to activate valve. Valve is direct acting, non-metering type and is optionally available as metering with non-hold open feature. Metering valve timing is adjustable from 5 to 60 seconds. Valve includes a 0.5 GPM flow control and can be remotely located up to 10 feet from the operating pushbutton. Valve and bubbler conform with lead free requirements for NSF61, Section 9 and CHSC 116875.

**Toilet** is blowout jet type with elongated bowl manufactured to ASME A112.19.3 and CSA B45.4 requirements and will flush with a minimum of 25 PSI flow pressure when used in conjunction with a minimum of 1.28 gpf. Trap has a minimum 3-1/2" seal and will pass a 2-1/8" ball. Toilet waste outlet is 2-3/8" diameter plain end extending 3" beyond the fixture for wall outlet or Gasketed Waste for floor outlet.

**Regularly Furnished** items include a fast drain, integral raised soap ribs, and mounting hardware.

**GUIDE SPECIFICATION**

Provide and install Acorn Penal-Ware® 15" wide Lav-Toilet Comby (specify model number and options). Fixture shall be fabricated of type 304 stainless steel. Construction shall be seamless welded and exposed surfaces shall have a satin finish. Countertop shall have raised soap ribs. Provide Air-control pneumatically operated pushbutton valve. Valve and bubbler conform with lead free requirements for NSF61, Section 9 and CHSC 116875. Toilet shall be concealed blowout jet type with an elongated bowl, a self-draining flushing rim, and an integral contoured seat. Toilet shall meet ASME A112.19.3 and CSA B45.4 requirements and will flush with a minimum of 25 PSI flow pressure when used in conjunction with a minimum of 1.28 gpf. Toilet trap shall have a minimum 3-1/2" seal that shall pass a 2-1/8" diameter ball and be fully enclosed. Cabinet interior is sound-deadened with fire-resistant material. Fixture shall withstand loadings of 5,000 pounds without permanent damage. Fixture shall be furnished with necessary fasteners for proper installation.

**Penal-Ware® 1415: 15" Lav-Toilet Comby with Lavatory Multi-Sided Bowl**



**NOTES:**

- |   |                                   |
|---|-----------------------------------|
| 1. -04 Hot & Cold Air-Control Valve Shown | 5. Optional -FV Flush Valve Shown |
| 2. Lavy Valve Pushbuttons                 | 6. Toilet Waste Outlet            |
| 3. Lavy -BP Penal Bubbler Shown           | 7. Wall Mounting Hardware         |
| 4. Lavy Waste Outlet                      |                                   |

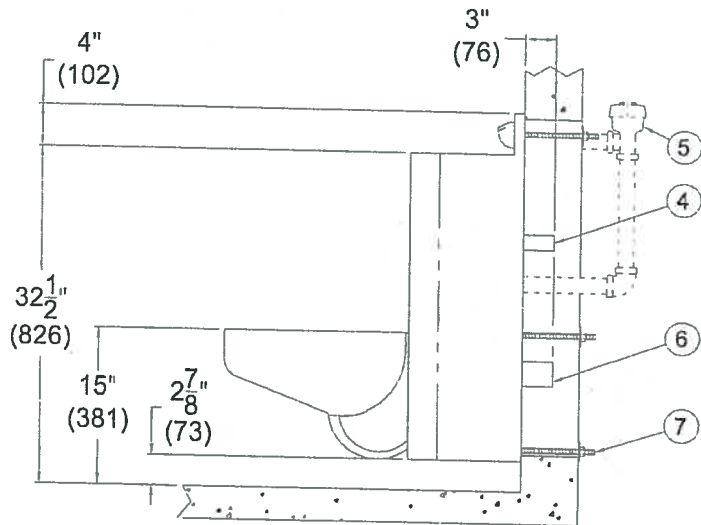
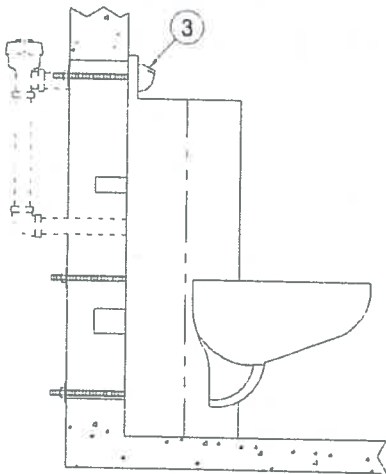
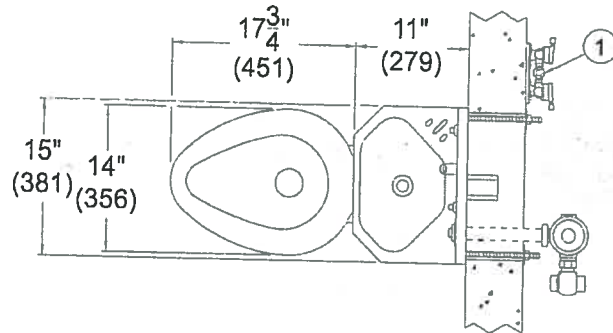
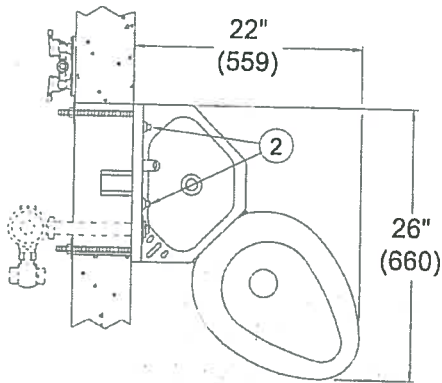

1415-AL-2-BP-04 SHOWN (-AR OPPOSITE)

1415-CT-1-BP-04



# Penal-Ware® 1415: 15" Lav-Toilet Comby with Lavatory Multi-Sided Bowl



### WALL THICKNESS AND TYPE (Must Specify)

Thickness: \_\_\_\_\_ Type:  Concrete  Block  Steel

### MODEL AND OPTIONS SELECTION:

#### BASE MODEL NUMBER

1415 15" Lav-Toilet Comby

#### TOILET ORIENTATION (Must Specify)

- AL Angled Left
- AR Angled Right
- CT Centered Toilet

#### FIXTURE MOUNTING AND WASTE (Must Specify)

- 1 Off-Floor, Wall Outlet
- 2 On-Floor, Wall Outlet
- 3 On-Floor, Floor Outlet

#### BUBBLER SELECTION (Must Specify)

- BC Bubbler, Code
- BP Bubbler, Penal
- BPH Bubbler, Penal Hemispherical
- LF Lav-Filler

#### VALVE SELECTION (Must Specify)

##### Air-Control (Pneumatic)

- 03 Single Temp, Non-Metering
- 03-M Single Temp, Metering
- 04 Hot & Cold, Non-Metering
- 04-M Hot & Cold, Metering
- 04-MH Hot & Cold, Metering Hot Side Only

##### Master-Trol® (Electronic)

- EVS1 Single Temp
- EVS2 Hot & Cold
- EVSP1 Single Temp, Piezo Button
- EVSP2 Hot & Cold, Piezo Buttons

##### Master-Trol® PLUS (Electronic)

- MTP1 Single Temp
- MTP2 Hot & Cold
- MTPP1 Single Temp, Piezo Button
- MTPP2 Hot & Cold, Piezo Buttons

##### -MTP VALVE OPTION

- PFB Power Failure Bypass (Provides drinking water in the event of power failure)

##### Time-Trol® (Electronic)

- MVC1 Single Temp
- MVC1-BAT Single Temp Battery Powered (Batteries Not Included)
- MVC2 Hot & Cold
- MVC2-BAT Hot & Cold Battery Powered (Batteries Not Included)

##### Programmable (Electronic) w/9VDC Plug-In Transformer

- PPZ1 Single Temp Programmable Piezo Button
- PPZ2 Hot & Cold Programmable Piezo Button

##### Valve By Others

- 9 Punched for Valve by Others

#### VALVE OPTIONS

- BRS Brass Body Valve
- CI Cycle Interrupt for Time-Trol® Valves
- MA2 Manifoldded, 2-Stack
- MA3 Manifoldded, 3-Stack (N/A with -PFB option)
- MA4 Manifoldded, 4-Stack (N/A with -PFB option)
- PBH Hemispherical Pushbutton
- PBP Pushrod Activated Pushbutton
- TF Transformer, 120VAC to 24VAC (-MVC option only)

#### FLUSH VALVE GPF's (Must Specify)

- 1.28 GPF (HET)
- 1.6 GPF (Not Available in California)
- 3.5 GPF (Not Available in California)

#### FLUSH VALVE OPTIONS (Must Specify)

- EVSVV Master-Trol® Electronic Flush Valve
- EVSPFV Master-Trol® Electronic Flush Valve w/ Piezo Button
- FV Flush Valve, Mechanical
- FVBO Flush Valve by Others
- FVH Flush Valve, Hydraulic
- MTPFV Master-Trol® PLUS Electronic Flush Valve
- MTPPFV Master-Trol® PLUS Electronic Flush Valve w/ Piezo Button
- MVCFV Time-Trol® Electronic Flush Valve

#### CABINET OPTIONS

- FMT Fixture Mounted Trim
- IS Integral Shelf
- PH Paper Holder, w/ -CT Centered Toilet  L  C  R
- Paper Holder w/ -AL / -AR Angled Toilet
- Left Front  Right Front
- TB Toothbrush Holder  Left  Right
- TG 12 Gage Cabinet
- TH Towel Hook  Single  Double  Left  Right
- VG1 Vent Grille 5-3/4" x 8-3/4"
- VG2 Vent Grille 8-3/4" x 13" (Bottom Only) (-1 Only)

#### LAVATORY WASTE OPTIONS

- CW Combined Waste
- LW1 Lavy Thru-Wall Extension With P-Trap
- LWE Lavy Waste Extension (3" Standard)
- Specify Length Beyond Fixture: \_\_\_\_\_
- OF Lavatory Overflow
- PT 1-1/2" Removable P-Trap

#### TOILET OPTIONS

- CO1 Cleanout w/ 2-3/8" OD O-Ring Connection to No-Hub 4" (Plain End Only, Not Applicable with -GW or -3 Floor Outlet)
- CO1-3 Cleanout w/ 2-3/8" OD O-Ring Connection to No-Hub 3" (Plain End Only, Not Applicable with GW or -3 Floor Outlet)
- COH Cleanout Hook Assembly
- FT Flood-Trol (Manual Reset)
- FTA Flood-Trol Auto-Reset
- FTE Flood-Trol Electronic
- FVT Flush Valve Thru Wall Connector
- FVO Flush Valve Opposite In Lieu Of Standard Location
- GW Gasketed Toilet Waste (Wall Outlet)
- HPS High Polished Seat
- HS Hinged Seat
- PC Pinned Cleanout Plug (For -CO1 Options above)
- SPS Ligature Resistant Skirt
- TSC Toilet Shipping Cover
- TWE Toilet Waste Extension (3" Standard)
- Specify Length Beyond Fixture: \_\_\_\_\_
- WO3B 2-3/8" P-Trap w/ 3" Plain End Waste Outlet

#### PRODUCT OPTIONS

- EG Enviro-Glaze Color Specify: \_\_\_\_\_
- Toilet Interior & Exterior
- EGE Enviro-Glaze Color Specify: \_\_\_\_\_
- Toilet Exterior Only
- LPFV Less Punching for Flush Valve
- MT Metal Template (Only 1 required per project)
- SW Wall Sleeve
- VAC AcornVac Systems

Please visit [www.acorneng.com](http://www.acorneng.com) for most current specifications.

**WARNING:** Cancer and Reproductive Harm - [www.P65Warnings.ca.gov](http://www.P65Warnings.ca.gov)

Important: Installation instructions and current rough-in are furnished with each fixture. Do not rough in without certified dimensions. Dimensions are subject to manufacturer's tolerance of plus or minus 1/4" and change without notice. Acorn assumes no responsibility for use of void or superseded data. © Copyright 2009 Acorn Engineering Company

Selection Summary	
Model No. & Option	_____
Quantity	_____

Approved for Manufacturing	
Company	_____ Title _____
Signature	_____ Date _____